



NSAI
Agrément

**IRISH AGRÉMENT BOARD
CERTIFICATE NO. 19/0412**

Metal Frame Construction,
Lismullen, Garlow Cross,
Navan, Co. Meath.
T: +353 (0)46 902 6911
W: www.metalframeconstruction.ie

Metal Frame Construction Steel Frame Building System

NSAI Agrément (Irish Agrément Board) is designated by Government to issue European Technical Assessments. NSAI Agrément Certificates establish proof that the certified products are '**proper materials**' suitable for their intended use under Irish site conditions, and in accordance with the **Building Regulations 1997 to 2023**.



PRODUCT DESCRIPTION:

This Certificate relates to the Metal Frame Construction (Metal Frame Construction) Steel Frame Building System, for the manufacture and erection of structural cold-formed Light Gauge Steel (LGS) Frame Buildings. The Metal Frame Construction Steel Frame Building System is certified to be used in the following purpose groups 1(a), 1(b), 1(c), 1(d), 2(a), 2(b), 3, 4(a) and 5 as defined in Technical Guidance Documents to Part B of the Building Regulations 1997 to 2023. The system is used for structural walls and floors in the above purpose groups up to 30m in height to the top storey or as part of a building not more than 30m in height to the top storey, where the full structure is designed, manufactured, supplied and erected by Metal Frame Construction Limited. The system can accommodate a wide range of custom designs.

The Metal Frame Construction System is also assessed for use in non-loadbearing infill panels. The infill panels are used within reinforced concrete, steel frames and traditional construction that possess their own independent lateral stability systems.

Site erection is carried out by approved installers employed by Metal Frame Construction or specialist sub-contractors under the supervision of Metal Frame Construction Ltd.

This Certificate certifies compliance with the requirements of the Building Regulations 1997 to 2023.

Readers are advised to check that this Certificate has not been withdrawn or superseded by a later issue by contacting NSAI Agrément, NSAI, Santry, Dublin 9 or online at <http://www.n sai.ie>

USE:

The system is certified for the following applications:

1. To provide the structure of a building up to 30m in height to the top floor, which can accommodate either a composite concrete profile metal deck or a cold formed section floor.
2. The system can also be used as the top storeys (Penthouse) of a building not more than 30m in height. The Metal Frame Construction Steel Frame element of the building must be constructed off a concrete floor or non-combustible podium/transfer slab.
3. Metal Frame Construction Steel Frame System non-loadbearing infill panels can be used in buildings not more than 30m in height where a fire resistance of 90mins is required (see Section 1 Part B of this Certificate). The infill panels can be incorporated in concrete or steel framed building systems which possess their own independent lateral stability systems.

DESIGN:

The Metal Frame Construction Steel Frame Building System is intended for use where architect's finalized construction and fire strategy drawings are available and satisfy the Building Regulations 1997 to 2023. The Architect and Engineer Design Team of the Developer (the Client) is responsible for the architectural drawings and overall building design to comply with the Building Regulations.

The Metal Frame Construction Steel Frame Building system is designed for use in permanent buildings with brick or block external finishes or with an NSAI Agrément approved external cladding system. The compatibility of an NSAI Agrément approved cladding system will be agreed and confirmed by Metal Frame Construction at design stage to ensure compatibility between both systems.

The Metal Frame Construction System is also designed for use with a wide range of traditional roofing finishes. The system may also be designed to incorporate NSAI Agrément approved alternative roofing systems. However, written approval must be sought from Metal Frame Construction Chartered Structural Engineers on the use of such roofing systems.

The buildings are assembled using a panellised system, factory-made and site installed. The Chartered Structural Engineers of Metal Frame Construction Ltd are responsible for the final design of the system.

MANUFACTURE, MARKETING & DESIGN:

The product is manufactured, marketed, designed and erected by:

Metal Frame Construction Ltd,
Lismullen, Garlow Cross,
Navan, Co. Meath,
C15 W6A0.

T: +353 (0)46 902 6911

W: www.metalframeconstruction.ie

1.1 ASSESSMENT

In the opinion of NSAI Agrément, the Metal Frame Construction Steel Frame Building System if used in accordance with this Certificate can meet the requirements of the Building Regulations 1997 to 2023, as indicated in Section 1.2 of this Irish Agrément Certificate.

1.2 BUILDING REGULATIONS 1997 to 2023**REQUIREMENTS:****Part D – Materials and Workmanship**

D3 – The Metal Frame Construction Steel Frame Building System, as certified in this Certificate, is comprised of ‘proper materials’ fit for their intended use (see Part 4 of this Certificate).

D1 – The Metal Frame Construction Steel Frame Building System, as certified in this Certificate, meets the requirements of the building regulations for workmanship.

Part A – Structure**A1 – Loading**

The Metal Frame Construction Steel Frame Building System once appropriately detailed, designed and constructed has adequate strength and stability to meet the requirements of this Regulation (see Part 3 of this Certificate).

A2 – Ground Movement

An appropriately designed ground floor or podium slab can safely sustain the combined dead, imposed and wind loads of the system into the foundation structure without causing undue deflection to any part of the building.

Part B – Fire Safety**Part B Vol 2 – Fire Safety**

For purpose group 1(a), 1(b) and 1(d), the fire safety requirements are laid out in TGD B Fire Safety Volume 2, Dwelling Houses of the Building Regulations 1997 to 2023. For purpose group 1(c), 2(a), 2(b), 3, 4(a) and 5 the fire safety requirements are laid out in TGD B (2020 reprint) to Part B of the Building Regulations 1997 to 2023.

For the Volume 2 Dwelling Houses, Part B6 – B11 are required to be adhered to, while for purpose group 1(c), 2(a), 2(b), 3, 4(a) and 5 Parts B1 – B5 are required to be adhered to.

B1 & B6– Means of Escape in Case of Fire

The Metal Frame Construction Steel Frame Building System is designed and constructed so that appropriate provisions for the early warning

of fire, and adequate means of escape in the case of fire from the dwelling, can be accommodated.

B2 & B7 – Internal Fire Spread (Linings)

The plasterboard side of walls and ceilings is designated Class 0 (National Class) or Class B-s3, d2 (European Class). It may therefore be used on the internal surfaces of buildings of every purpose group without restriction.

B3 & B8 – Internal Fire Spread (Structure)

The building system is designed and constructed so that its stability will be maintained for a reasonable period in the event of fire in compliance with Section B3 of TGD B (2020 reprint), and section B8 of TGD B Vol 2 2017, to Part B of the Building Regulations 1997 to 2023.

B4 & B9 – External Fire Spread

External masonry walls shall have a Class 0 surface spread of flame rating and when installed and used in the context of this Certificate will provide adequate resistance to the spread of flame over the external walls and roofs and can satisfy the relevant requirements of this Regulation as indicated in Section 4.1.3 of this Certificate.

Note: In a building more than 18m high, insulation material used in drained and unventilated cavities in the external wall construction should be of limited combustibility (see Appendix A TGD B (2020 reprint)).

B5 & B10 – Access and Facilities for the Fire Service

The provision of access and facilities for the fire service is outside the scope of this Certificate.

Part C – Site Preparation and Resistance to Moisture**C3 – Dangerous Substances**

Each dwelling ground floor must include a radon sump and provide the facility for radon extraction. Where it is shown that protection from dangerous substances e.g. radon, is required, an approved gas resistant membrane and gas handling system must be provided under the ground floor. The Metal Frame Construction Steel Frame Building System permits the incorporation of the appropriate membrane, sump and gas handling system.

C4 – Resistance to Weather and Ground Moisture

The Metal Frame Construction Steel Frame Building System has adequate damp-proof courses and membranes to resist the passage of moisture from the ground.

Roofs and external walls above site Damp Proof Course (DPC) level will have adequate weather resistance in all exposures to prevent the passage of moisture from the external atmosphere into the building as specified in Section 4 of this Certificate.

Part E – Sound

E1 – Airborne Sound (Walls)

Walls can be appropriately detailed and constructed to meet the airborne sound level performance outlined in Table 1 of TGD E of the Building Regulations 1997 to 2023, provided good workmanship is adhered to onsite. (See Section 4 of this Certificate).

E2 & E3 – Airborne and Impact Sound (Floors)

Separating floors can be constructed to meet the airborne and impact sound level performance outlined in Table 1 of TGD to Part E of the Building Regulations 1997 to 2023 provided good workmanship is adhered to on site.

Part F – Ventilation

F1 (a) – Means of Ventilation

Adequate ventilation openings are provided in internal and external walls and in roofs to meet this requirement. Walls and roofs used in the system can be designed and constructed to prevent any harmful effect from interstitial or inner surface condensation, to comply with the requirements of BS 5250^[1].

F1 (b) – Limiting the concentration of harmful pollutants in the air within the building

The ventilation rate is required to be designed to meet the level of air pollutants present in the building. This will be based on the project specific design.

F2 – Condensation in Roofs

Adequate ventilation is provided in roofs to meet this requirement (see Section 4 of this Certificate).

Part J – Heat Producing Appliances

J1- Air Supply

The system can provide an adequate supply of permanent combustible air by means of air ducts, to obviate draughts, within the room in which the fireplace is located.

J3- Protection of Building

When used in accordance with Section 4 of this Certificate, specified separation distances from wall lining insulation meet the Building Regulation requirements.

Part L – Conservation of Fuel and Energy

L1 – Conservation of Fuel and Energy

The Metal Frame Construction Steel Frame Building System can be readily designed to incorporate the required thickness of insulation to meet a wide range of required elemental u-values. The elemental u-values are calculated using the elemental heat loss method calculations for walls as per TGD to Part L of the Building Regulations 1997 to 2023 (see Section 4.2).

The system can readily be detailed to accommodate a wide variety of plan forms and users of the system must ensure that Building Regulation requirements (avoidance of cold bridging) that are affected by plan form and internal sub-division of the building are complied with.

Thermally bridged junctions have been assessed for both their linear thermal transmittance (i.e. Psi-value (ψ -value) and their temperature factors (f_{Rsi}) in accordance with the procedures outlined in IP 1/06 "Assessing the effects of thermal bridging at junctions and around openings"^[2] and BRE report BR 479 "Conventions for calculating linear thermal transmittance and temperature factors"^[3] and IS EN ISO 10211^[4]. As a result, best practice has been observed to limit heat loss due to thermal bridging and minimising the risk of mould growth due to surface condensation.

Part M – Access for People with Disabilities

M1 – Access and Use

Buildings can be designed to meet the access, circulation and facilities requirements of this Regulation (see Section 4.6 of this Certificate).

M2 – Sanitary Conveniences

Buildings can be designed to meet the installation requirements for sanitary conveniences for people with disabilities (see Section 4.6 of this Certificate).

2.1 PRODUCT DESCRIPTION

This Certificate relates to the Metal Frame Construction Steel Frame Building System for the design, manufacture and erection of cold-formed light gauge steel frame buildings. Buildings using this system are erected on site using a panelised system factory made and site installed with all major custom components being manufactured at Metal Frame Construction production facility.

Metal Frame Construction produces all cold-formed steel sections using (CNC) computer numerically controlled plant. Insulation is placed on the cavity side of the cold formed steel studs and the insulation serves to encase the cold formed steel sections thus creating a "warmframe" environment for the steel frame.

2.1.1 External Walls

The external walls can be load bearing or non-load bearing. Insulation is fitted to the cavity side of the cold formed steel studs. The wall panels are filled with stone mineral wool insulation between the studs for acoustic and fire performance. The wall panels are then clad with the required thickness and grade of plasterboard as per Table 4 to achieve the appropriate fire rating required for the building. The plasterboards are screw fixed to the cold formed steel stud and track members.

The requirements for the provision of an Air and Vapour Control Layer (AVCL) on external walls are outlined in Section 4 of this Certificate.

2.1.2 External Cladding

The external leaf of the Metal Frame Construction Steel Frame Building System can be constructed of a number of construction types:

- The Metal Frame Construction Steel Frame Building System with insulation, the required cavity width and traditional block/brick to IS EN 1996-1-1^[27] Eurocode 6 and S.R. 325^[5]
- The Metal Frame Construction Steel Frame Building System with insulation and NSAI Agrément approved external cladding system.

2.1.3 Wall Ties

Where traditional block or brick is used as part of the Metal Frame Construction Steel Frame Building System, the masonry outer leaf is tied to the steel frame building system with a stainless-steel channel and cavity wall tie system in accordance with IS EN 845-1^[6]. The tie is intended to be used in masonry to studded applications, with a design cavity in accordance with IS EN 1996-1-1^[27].

The cavity width is defined as the distance between the outer surface of the insulation and the inner surface of the masonry leaf. The wall tie system comprises of two parts, the channel which is factory fitted through the insulation with the required depth of tech screw directly into the flange of the cold formed studs, and the wall tie which is site fitted by the mason. The wall tie channels are fitted at each cold formed steel stud at a frequency that can accommodate the requirements for wall tie spacing as outlined in IS EN 1996-1-1+NA (National Annex)^[27] Eurocode 6.

Using this channel system allows for variations within block/brick courses. Around openings, channels are positioned within 150mm of the opening, and line up with the steel studs. The slot in the wall tie bracket enables a wall tie to be adjusted vertically for variations in mortar thickness during construction of the masonry outer leaf. Additional wall ties are provided at 225mm centres around all openings, corners and movement joints, such that there is a tie for each 225mm of perimeter of opening or either side of each movement joint/corner. Stainless steel wall ties are available as standard flat ties with drip.

The wall ties have been assessed and meet the performance requirements given IS EN 845-1^[6] for a Type 6 wall tie and designed in accordance with IS EN 1996-1-1+NA^[27]. Where masonry cladding is being used over 4 storeys' (12m) in height, a Type 1 wall tie in accordance with I.S. EN 845-1^[6] must be used. The wall tie and channel are made from minimum Grade 304 austenitic stainless steel and designed according to I.S. EN 1993-1-1+NA^[22] and I.S. EN 1993-1-4+NA^[24].

The cavity in the external wall must be maintained and kept clear of construction debris to 150 mm below DPC level. Masonry claddings must have adequate weep holes along their base and over openings to allow moisture to exit the cavity.

2.1.4 Internal Walls

The internal load bearing and non-load bearing wall panels are made from cold-formed LGS. When internal wall panels provide racking resistance to external walls, diagonal wind bracing members can be incorporated into the panel to successfully transfer the horizontal loads safely through the building structure in accordance with structural design requirements. The bracing also serves to keep the frames square during erection.

All internal load bearing panels must be sufficiently supported directly under the panels with rising blockwork or equivalent. Plasterboard specifications on the steel panels should be in accordance with Table 4 of this certificate, which shows the plasterboard fire resistance requirements for wall, floor and ceiling elements. The plasterboard and AVCL (where required) linings are fixed to the walls and ceilings by means of self-drill/self-tap screws; all joints are then taped and filled where required for decoration.

2.1.5 Compartment Floor

Compartment floors as described in Table 4 of this Certificate will have a prescribed fire-resistant classification which can be used in the separation of one fire compartment from another.

The construction of C-joist/truss compartment floors must be such that the achievement of the required fire resistance performance relies primarily on the integrity of the linings of such constructions. The compartment floor is constructed of LGS floor joists with OSB or Plywood decking. Fire protection is provided by plasterboard to the underside of the ceiling in accordance with Table 4. The integrity of linings of compartment floors should not be breached to allow for the installation of services (e.g. pipes, wires, flues, including manufacturing flues), except where necessary to allow services pass through these compartment floors. Where services pass vertically through compartment floors, they should be adequately fire stopped in accordance with the respective TGD to Part B of the Building Regulations 1997 to 2023 to which the relevant purpose class relates – all service penetrations in the ceiling such as down-lighters, soil vent pipes and ventilation duct heads must be fire stopped by the use of fire collars, fire hoods or fire rated products. Composite metal deck floor provides its own fire resistance and is based on the concrete cover to the steel reinforcement.

Services can be accommodated within a service cavity created external to the un-breached linings of the fire-resistant compartment floor on the underside of the ceiling below.

For additional acoustic performance, resilient bars may be added where specified and are fixed to the underside of the floor trusses/C-joist in order to maintain the fire integrity of the floor in accordance with fire performance details outlined in Table 4.

2.1.6 Roof Structure

The roof trusses can be either a traditional timber cut roof or prefabricated roof truss made from timber or steel. The site fitted timber roof trusses

are attached to timber wall plates, which are bolted on site to the top wall track of the load bearing Metal Frame Construction wall panel. The Metal Frame Construction cold formed roof trusses can be fixed down directly with a thermal break onto the top wall track of the load bearing Metal Frame Construction wall panel.

Roofs may be clad with concrete or clay interlocking tiles or slates. The imposed load on the roof is project specific and is accounted for in the design of the steel frame structure.

2.1.7 Chimney Construction

Metal Frame Construction Steel Frame Building System can incorporate both traditional block/brick chimney construction or an NSAI Agrément approved pre-fabricated chimney system in accordance with its NSAI Agrément Certificate and the Building Regulations 1997 to 2023.

2.1.8 Internal Linings and Finishes

Linings to walls and ceilings are of plasterboard of Type F as specified in Table 4, manufactured to IS EN 520^[11]. They are attached by means of self-drill/self-tap screws into steel members. In areas prone to high levels of humidity, moisture resistant plasterboard should be used. Joints in plasterboard can be taped and filled in accordance with the plasterboard manufacturers' instructions for direct decoration. Alternatively skim coat plaster can be applied. Any wall mounted fitting to the wall other than lightweight items, e.g. framed pictures, must be fixed into a proprietary ground, using appropriately sized proprietary fixings. To accommodate larger wall mounted fittings such as kitchen units or proprietary grounds can be provided between LGS studs.

2.2 GENERAL BUILDING STRUCTURE

2.2.1 Foundations

Foundations are outside the scope of this Certificate. Based on finalised layouts, the Metal Frame Construction Structural Engineer can carry out a load take down calculation and provide the Client appointed Structural Engineer with accurate line loads which they can accommodate into their foundation design.

Metal Frame Construction Steel Frame Building System may be used with a variety of foundation types, including NSAI Agrément approved foundation systems. The foundation system will be selected depending on the ground conditions encountered on site. A site investigation should be carried out by an appropriately qualified and experienced Engineer to determine the maximum bearing pressure the soil can carry. Once this is established a suitable foundation type can be selected. A tolerance of $\pm 5\text{mm}$ in 10-meter lengths is specified for both concrete slab level

and horizontal dimensions. Where variations in slab level occur, such variations are catered for using structural steel packers located directly below the studs as required. However, the use of such packers should be kept to a minimum. The remaining gaps below the steel frame panel sole plate are filled using structural grade non-shrink grout.

Note: The construction of the foundations and ground floor slab are the responsibility of the main Contractor and should be constructed in accordance with the Client's Engineering specifications. Due to the low tolerances of the steel frame manufacture, the foundation and ground floor slab must be constructed accurately, i.e. correct dimensions, square and level so that the steel frame system can be erected properly within the specified tolerances.

2.2.2 Ground Floor

An in-situ concrete slab may be used to form the ground floor. Below the concrete slab, insulation is provided to meet the requirements of TGD to Part L of the Building Regulations 1997 to 2023, including the avoidance of cold bridging. An NSAI or equally approved radon resistant membrane is installed in accordance with Clause 8 of IS EN 1996-1-1^[27] and BS 8102:2022^[8], to protect the floor and bottom channels of the steel studs from rising damp. Alternatively, a proprietary suspended ground floor may be used, provided it is approved by the Metal Frame Construction Structural Engineer for use with the Metal Frame Construction Steel Frame Building System to meet the required structural loads criteria (dead load, uplift, etc.). The structural design of the ground floor should be in accordance with Part 3 of this Certificate.

2.2.3 Concrete Podium Slab (Transfer Slab)

Where the Metal Frame Construction Steel Frame Building System is constructed off a concrete podium slab, a tolerance of $\pm 5\text{mm}$ is required on the podium slab line and level. Procedures for variations in slab are as described in Section 2.2.1 of this Certificate. The construction of the podium slab is the responsibility of the main contractor and the design is the responsibility of the Client's Engineer, who will require line loads from the Metal Frame Construction Structural Engineer. The Metal Frame Construction Steel Frame Building System certification applies from the transfer slab level upwards.

2.3 DESIGN AND MANUFACTURE

2.3.1 Design Process

Before a Metal Frame Construction Steel Frame Building can be manufactured a Chartered Structural Engineer must complete the structural design including the specification of all members. The Client's architectural drawings are received

by Metal Frame Construction Ltd and converted into a 3D structural computer aided design model (CAD/CAM). This system automatically calculates all framing requirements for walls, floors, roof trusses (where required), and allows for all openings such as doors and windows. Each individual frame member is allocated a unique identification number and has its length calculated, along with the position of any cut-outs, punch holes or bracket positions. The Metal Frame Construction Structural Engineer checks and signs off all drawings to ensure structural compliance before any drawings are transferred to production. Once the drawings have been cleared for production they are transferred to the computer which operates the roll-forming equipment.

Elements	Tolerance
Length	$\pm 2\text{mm}$ per panel length
Opening position	$\pm 2\text{mm}$
Size of openings	+5mm -0mm
Frame squareness	$\pm 2\text{mm}$

Table 1: Manufacturing Tolerances

2.3.2 Roll-Form Production

The roll-formers use computer aided manufacturing (CAM) techniques to process the data, which has been transferred from the design office to the roll former. The steel coil is then formed into the required shapes, with the position of cut-outs, punch-holes etc. being accurately located within a tolerance of $\pm 2\text{mm}$ per 10m length. Individual members are grouped into bundles as they come off the roll-forming equipment, corresponding to their subsequent handling in the assembly process. Assembly of the components can commence in the factory directly after it has been roll-formed or the components can be transferred in flat pack form for assembly elsewhere by Metal Frame Construction approved assemblers.

2.3.3 Wall Panel Assembly

The steel frame panels are composed of galvanised mild steel manufactured from galvanised coil as described in Section 2.4.2. All profiles are designed in accordance with IS EN 1993-1-3^[23] Eurocode 3 (including Irish National Annex). Section properties comply with IS EN 10162^[32]. The wall panels have vertical, C-channel studs at centres required by design, which are fixed to top and bottom horizontal channels using rivets/screws. The rivets/screws are precisely located in pre-punched holes in the studs, which match holes in the top and bottom channel. The pre-punched holes in the studs are dimpled which allows the flat-topped rivets/screws to be flush with the metal surface.

Where rivets are used in the assembly of wall panels in the factory, i.e. stud to track connections, it is important to note that these rivet fasteners have not been considered in the structural performance of the panels. It is structurally acknowledged that the rivets will contribute to the structural performance of the panel with increased stiffness in particular, but this has not been considered in the structural design calculations of the panel. Where structural elements are added to the wall panels such as wind bracing, wall tie brackets and lintel platers, these must only be fixed with approved Tek screws as these are structural connections and must be designed and installed in accordance with the Structural Engineers design drawings.

2.3.4 Floor Cassette Assembly

The use of floor cassettes is project specific, with cassettes often being used for mid-rise multi-storey buildings.

Floor cassettes are factory assembled and delivered to site. Floor cassettes are made from either LGS floor joists or LGS trusses. Where LGS trusses are used, bolts are used to connect the LGS members. A floor decking is screwed to the top of the cassette. The floor cassettes are either supported on vertical wall panels, hung on Z-hangers or supported by C-channels at the end of the joists or trusses.

The solution adopted is chosen by Metal Frame Construction or the Client's Project Structural Engineer.

2.3.5 Quality Control Production

Quality control carried out during manufacture includes visual inspection of steel coiled raw material, calibration of roll forming equipment daily, cross checking of all in-house production drawings, and checks on production dimensions (length, width and steel thickness) and on the dimensions and squareness of finished panels.

Each panel is assembled from an individual fabrication drawing and when the panel is complete the drawing is signed by the assembler and a panel identification sticker is placed on the panel. The identification can also be printed on the stud as it is being rolled in the roll former.

A file is created for each project which contains all the panel drawings signed off, a steel identification form, the machine calibration forms and any other information available on the project.

2.4 STRUCTURAL PRINCIPLES

2.4.1 Steel Frame Structure

The basis of the typical Metal Frame Construction structure is a cold-formed light gauge steel frame, which is assembled into panels in the

factory and installed on site. The design, manufacture, assembly and erection of the system is based on the combined services of BIM (Building Information Modelling) and CNC software, which feeds the required code into the proprietary roll-formers and produces the documentation required to manufacture and install accurately.

The panels are fabricated from suitably coated steel coil as described in Section 2.4.2 which is formed into the required shapes by proprietary roll-forming equipment. The frequency and size of the structural elements will depend on the individual panel and truss (floor or roof) design. The individual elements manufactured are then assembled by trained personnel to produce the required wall or truss (floor or roof) with fixings as specified within the system design by the Structural Engineer.

The wall panels, where required by design, will have ancillary elements assembled into them such as strap or 'K' bracing, lintel trusses over openings and insulation on the external walls which are described in this Certificate.

Typically, the Metal Frame Construction steel frame building system utilises steel roof trusses. These are produced by Metal Frame Construction Ltd and the fixings are specified by the Structural Engineer. Pre-fabricated timber roof trusses can be utilised in Metal Frame Construction structures where required. Timber roof trusses are designed and supplied by others.

The grades of steel and dimensions of sections used are selected and specified by a Metal Frame Construction Chartered Structural Design Engineer in accordance with design requirements. Table 2 shows typical section sizes utilised for load bearing walls, non-loadbearing walls and trusses (floor or roof) for the cold formed steel elements of their system.

Section properties are calculated using design core thickness of steel (excluding coatings) in accordance to IS EN 1993-1-1^[22], IS EN 1993-1-3^[23] and IS EN 1993-1-5 including the respective National Annex^[25].

2.4.2 Protective Coatings

The steel frame members are all coated with a protective zinc-rich metal coating. The steel frame members are manufactured from galvanized coil steel to IS EN 10346:2015^[9] (min. yield stress 350 N/mm²) with 275 g/m² zinc protection for external structure and Z100, G280 for internal non-structural elements.

In addition to the steel members in the system being protected by zinc rich protective coatings, further protection against corrosion and longer

design life is given to the steel by providing the following:

- The bottom channel on all ground floor steel frame panels is additionally protected by a DPC.
- The insulation keeps the steel in a “warmframe” environment, which, in conjunction with an internal or external AVCL (where required, see Section 4.4.1 of this Certificate), prevents the formation of condensation within the wall structure.
- The metal and timber in the roof trusses are kept free from prolonged moisture build up, by means of free air circulation in the roof space, using ventilation methods in accordance with section F2 of TGD to Part F of the Building Regulations 1997 to 2023.
- Where steel is cut on site or where the coating of the steel becomes damaged, it is protected by the application of a zinc rich paint.
- All fasteners have been assessed and tested for use with the system, to ensure the minimum 50-year design life of the system per the Eurocodes.

2.4.3 Fasteners and Connection Joints

The unique design of the Metal Frame Construction Steel Frame Building System allows for no welding of joints in the system. The system is assembled using fasteners such as screws or bolts. Only self-drilling Tek screws are used for the structural connectivity of the system on site. On-site structural connections such as panel to panel connections, OSB boarding to floor joist, floor joist to panel, composite deck to panel and wind bracing are fastened using approved Tek screws.

All fasteners used in the steel frame system are adequately protected against corrosion i.e. galvanising/zinc coating and made from a suitable metal to ensure the design life of the system is maintained.

Metal Frame Construction Ltd provide a full specification of all fasteners, where they are to be used and how they are to be installed during the construction of the system. Only system fasteners approved or supplied by Metal Frame Construction Ltd may be used with the system. It is important to ensure that protective coatings on fasteners are not removed, i.e. to assist the fitting of a connection, as this would severely compromise the corrosion performance of the fastener. Where a building is located within one kilometre of the coastline and has a steel roof, all fasteners at the eaves shall additionally be coated with a zinc rich paint to protect against coastal spray or fasteners used that have the required salt spray test for this application.

2.4.4 Loadbearing Walls Structural Principles

The perimeter walls can be the primary load bearing elements of the structure and are therefore designed to bear on the walls of the panels below, i.e. permanent and variable imposed loads are transferred by load bearing external wall panels and if required load bearing internal wall partitions where necessary.

The load bearing wall panels are comprised of vertical studs, fixed to horizontal head and bottom channel sections. Horizontal noggins are fitted to panels where required to provide additional strength. Under high concentrated loads, studs can take multiple forms including, but not limited to, back to back formations and box formations, amongst others. The formation for a particular project is decided by the Metal Frame Construction Structural Engineer’s particular design.

Where windows are present a cold formed lintel or hot rolled section is provided to allow the load to transfer to the vertical wall studs. The design loads from each level are transferred through the primary load bearing elements into the substructures / foundations. Perimeter steel Z or C sections can be used to support floor joists/trusses and can also be designed to act as a lintel over openings.

HRS (Hot Rolled Steel) structural members may also be incorporated into the design of the wall panels as required to accommodate more complex structural designs. Any HRS structural members used as part of the Metal Frame Construction Steel Frame Building System must be fabricated in accordance with IS EN 1090-1^[10] and in accordance with execution class specified in the project specific design.

2.4.5 Racking

Resistance to horizontal loading (racking) is provided by the horizontal diaphragm action of the approved floor sheeting and roof in conjunction with the metal diagonal cross-bracing or K bracing members on specific external inner leaf and internal walls. All cross-bracing or K bracing is pre-assembled in the factory and has the dual function of ensuring squareness of factory produced panels in addition to providing lateral stability for the overall structure. Metal Frame Construction Ltd use both strap and K bracing.

Component Type	Grade of Steel	Typical Section Dimensions			
		Depth (h)	Width (b)	Lip (c)	Thickness ¹ (t)
Wall Stud	S350, S390, S450, S550	63	35	8	0.5 – 1.0
Wall Stud	S350, S390, S450, S550	90	46	10 – 12	0.75 – 2.5
Wall Stud	S350, S390, S450, S550	140	46	10 – 12	0.75 – 2.5
Wall Track/Noggin ²	S350, S390, S450, S550	90	46	10 – 12	0.75 – 2.5
Wall Track/Noggin ²	S350, S390, S450, S550	140	46	10 – 12	0.75 – 2.5
Floor Truss (C-Section)	S350, S390, S450, S550	200 – 350	90	10 – 12	0.75 – 2.5
Floor Truss (C-Section)	S350, S390, S450, S550	200 – 350	140	10 – 12	0.75 – 2.5
Floor Truss (Top Hat 52)	S350, S390, S450, S550	200 – 350	39	0 – 14	0.75 – 2.5
Floor Truss (Top Hat 76)	S350, S390, S450, S550	200 – 350	39	0 – 14	0.75 – 2.5
Floor Joists (C-Section)	S350, S390, S450, S550	200 – 300	50	10 – 14	0.75 – 3.0
Floor Track End Bearer (Z Track)	S350, S390, S450, S550	200 – 500	50 – 100	0	1.5 – 3.0

¹ The range of thickness of cold formed section available ranges from 0.5 to 3.0mm.

² Range of Depth (h) and Width (b) available to allow for uniform cross section of structural zone.

³ These profiles are standard; other special profiles are available on request.

Table 2: Typical Sized of Elements in the Steel Frame System

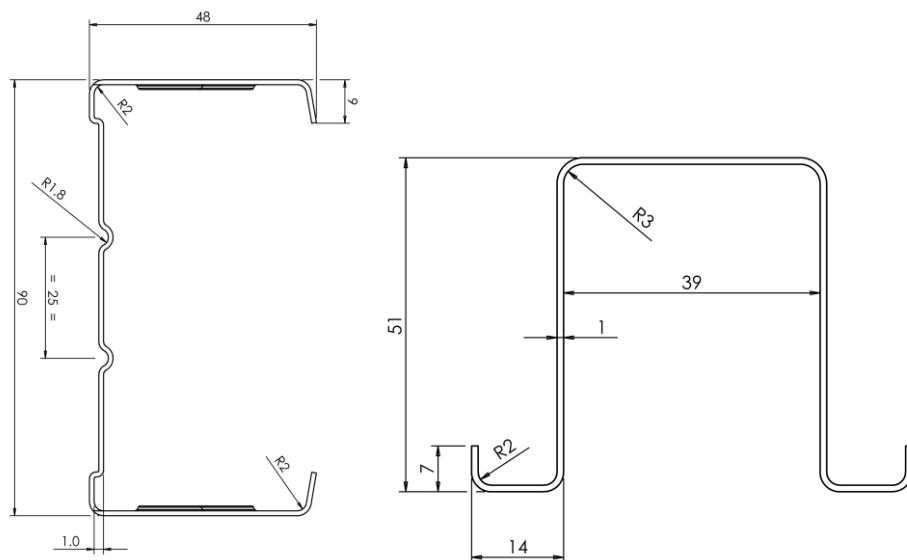

Figure 1: Channel with and without Lip

2.4.6 Holding Down

To provide resistance to uplift, the bottom channel of the external panels is fixed to the ground floor slab, podium slab or rising wall with approved fixings. The type of fixing used to hold down the panels of the system will be dependent on what substrate the fixing is being fixed to. These fixings are designed by Metal Frame Construction Structural Engineer and are installed in accordance with the *Code of Practice for the*

Design and Installation of Anchors in accordance with section 60 of the Safety, Health and Welfare at Work Act 2005^[47]. The positions of the fixings are project specific and are determined by Metal Frame Construction's Chartered Structural Engineer. The plasterboard is site applied allowing access for the fixings to be installed on site.

2.5 COMPARTMENTATION

2.5.1 Separating Wall (Party Wall)

Separating walls (party walls) are constructed using a minimum of two independent cold formed steel framed leaves with a recommended minimum cavity of 40mm between both frames. The individual frames are boarded (on site or in the factory) with the appropriate level of boarding required to provide the acoustic and fire properties as shown in Table 4. The LGS studs are filled with the appropriate mineral wool insulation from ground floor to the underside of the roof structure to provide the required fire and acoustic properties.

Where the attic space is habitable the stone mineral wool must go up to the underside of the roof for acoustic and fire purposes. Where the party wall abuts an external wall, the mineral wool insulation is provided in the cavity between the frames. It extends 300mm into the building and protrudes to meet the internal face of the external wall. This detail seals air gaps and minimises flanking sound transmission along with closing the cavity at this junction.

At the junction of the compartment floor and the party wall, an additional 500mm section of mineral wool insulation is provided within the cold formed section zone each side of the cavity mineral wool to minimise flanking and direct sound transmission and provide additional fire protection.

The head of the party wall must also be fire stopped and cavity closed as specified by the Metal Frame Construction details. Where services are required in a party wall, they can be accommodated by creating a service cavity to the party wall with timber battens or metal top hat sections and plasterboard. All battens used with the Metal Frame Construction system are treated in accordance with BS 8417^[12].

For purpose classes 1(a), 1(b) & 1(d), design must comply with the requirements of Section 3.5 of TGD B Volume 2 (2017) to Part B of the Building Regulations 1997 to 2023. For purpose classes, 1(c), 2(a), 2(b), 3, 4(a) and 5, design must comply with the requirements of Section 3.2.5 of TGD B (2020 reprint) to Part B of the Building Regulations 1997 to 2023.

2.5.2 Single Frame Compartment Walls

A compartment wall within the Metal Frame Construction Steel Frame Building System can be constructed of a single steel frame wall. This wall can be used in situations where a building is subdivided into different compartments, but this compartment wall **must not** be used where a wall is common to two or more buildings (separating wall) or where a compartment wall is used to separate dwellings from each other

within a building. The single frame compartment wall must be designed and specified to meet the acoustic and structural requirements set out in TGD A and TGD E, respectively. For purpose classes 1(a), 1(b) & 1(d), design must comply with the requirements of Section 3.5 of TGD B Volume 2. For purpose classes, 1(c), 2(a), 2(b), 3, 4(a) and 5, design must comply with Section 3.2.5 of TGD B (2020 reprint) to Part B of the Building Regulations 1997 to 2023.

No services are allowed to run vertically within the compartment wall and where services are required in a compartment wall, they can be accommodated by battening out the wall with timber battens or with resilient bar similar to accommodating services in a party wall. Services however can pass horizontally through a compartment wall, but they must be appropriately protected in accordance with Section 3.5.4.1 of TGD B 2017 Volume 2 (2017) for purpose class 1(a), 1(b) & 1(d) and in accordance with Section 3.2.5.7 and 3.4 of TGD B (2020 reprint) for all other purpose classes to which this certificate applies. Services passing horizontally through compartment walls should be kept to a minimum and avoided where possible.

2.5.3 Compartment Floors

The Metal Frame Construction Steel Frame Building System compartment floor can be designed to provide 60 minutes or 90 minutes fire resistance from the underside. There are two forms of compartment floors used with the Metal Frame Construction Steel Frame Building System:

- a) Steel Lattice Truss or C-joists protected with Plasterboard.
- b) Steel Concrete Composite Deck.

Compartment Floor Steel Lattice Truss or C-joists Protected with Plasterboard

The structure of a compartment floor used with the Metal Frame Construction Steel Frame Building System consists of cold formed steel lattice trusses or C-joists.

The construction of compartment floors must be such that the achievement of the required fire resistance performance relies primarily on the integrity of the linings of such constructions. The integrity of linings of compartment floors should not be breached to allow for the installation of services (e.g. pipes, wires, flues, including manufacturing flues), except where necessary to allow services pass vertically through these compartment floors. Where services pass vertically through compartment floors, they should be installed in accordance with Section 3.2.5.7 and Section 3.4 of TGD B (2020 reprint) to Part B of the Building Regulations 1997 to 2023.

Services may be surfaced mounted or accommodated in service ducts or within service cavities created externally to the un-breached linings of the fire-resistant compartment floor.

The compartment floor construction can comply with Part E of the Building Regulations 1997 to 2023 through the appropriate use of gypsum boarding, mineral wool insulation between the steel lattice trusses or steel C-joists, while maintaining the fire performance of the compartment floor. Further improvements to acoustic reductions can be achieved by using resilient bars between the ceiling and the plasterboard where appropriate and without compromising the fire performance of the floor.

Where a steel lattice truss type floor is supplied as a non-compartment floor, services can be catered for through the lattice diagonals, but these services must be fire sealed.

Compartment Floor Steel Concrete Composite Deck

The floor is constructed of a composite profiled metal deck which is fixed to the head track of the supporting load bearing walls. Steel reinforcement is installed on top of the deck as required by the design, and the required concrete thickness is then poured as required by the design.

An additional layer of resilient material is added to the top of the composite slab to meet the requirements outlined in Section 4.4 of TGD to Part E of the Building Regulations 1997 to 2023 (see Section 4.4.2.1 of TGD to Part E for definition of resilient material). The underside of the deck is fitted with the ceiling type required by the specific project. A Metal Frame Construction ceiling providing up to 300mm service cavity can be provided to accommodate services below ceilings provided the services are supported by the underside of the floor.

Fire Resistance of Steel/Concrete Composite Deck

The fire resistance of the composite deck is provided from the underside of the deck. The composite deck can provide up to 90 minutes' load bearing fire resistance from a combination of the reinforcement steel bars within the trough of the decking and adequate concrete cover to the reinforcement steel bars in question.

The additional layers of plasterboard will provide additional fire protection but is not considered in the fire resistance performance. The composite deck compartment floor is suitable for use in all purpose groups to which this Certificate relates.

All electrical and ventilation services are installed to the underside of the deck. The fire stopping of holes in the composite deck floor slab to accommodate pipes passing through a compartment floor (unless the pipe is in a protected shaft) should comply with Section 3.4 of the TGD B (2020 reprint) to Part B of the Building Regulations 1997 to 2023.

2.5.4 Forming Holes in Profiled Decks

When holes or opes to accommodate service penetrations are required, these can be incorporated in the composite concrete slab design prior to pouring the structural concrete. When additional opes are required, the size and exact location must be signed off by the Chartered Structural Engineer who designed the concrete slab.

2.5.5 Exposure of Metal Decks

Steel concrete composite decks are intended for internal use within the building envelope. Where design requires the metal deck to be exposed to the external environment, such as in a balcony situation, the metal deck needs to be thermally insulated to provide required u-value and limit thermal bridging. In addition, it should be suitably weather protected in accordance with the project specific design.

2.5.6 Cavity Barriers and Fire Stops

To meet the requirements of TGD to Part B Volume 2 of the Building Regulations 1997 to 2023 and TGD B (2020 reprint) to Part B of the Building Regulations 1997 to 2023, the correct specification and placement of cavity barriers and fire stops shall be detailed and shown on a schedule for the project. Typically, cavity barriers and fire stops should be provided in the construction of steel frame walls as follows:

- Separating walls shall have a vertical cavity barrier sealing the cavity at the wall ends, running from DPC level to the underside of the fire stopping at the top of the wall.
- At a separating wall junction with the external wall, the vertical cavity barrier runs out to the inner face of the external cladding and held in place with timber battens to form the cavity barrier.
- Horizontal cavity barriers shall be placed at the perimeter of all compartment floors. The cavity barrier should be appropriate for the external cladding that is intended to cavity close in the event of a fire or smoke entering the cavity (see Figure 10).
- A cavity barrier shall cover the full ceiling depth as well as the upper wall panel rail and lower wall panel head plate.
- Cavity barriers are required around all openings in external walls such as doors, windows, vents, extractor fans, meter cupboards, etc.

- The integrity of compartment/separating walls within roof voids that are continuous with the compartment wall between apartments, or continuous with a separating wall between dwellings, is essential to prevent fire spread. These walls must be fire stopped at the wall/roof junction to afford a minimum 90 minutes fire resistance. The method of fire stopping should be in accordance with guidance given in Diagram 10 of TGD B Volume 2 to Part B of the Building Regulations 1997 to 2023 for purpose groups 1(a), 1(b) and 1(d), and Diagram 13 of TGD B (2020 reprint) for all other purpose groups for which this Certificate applies.

2.5.7 Fire Stopping Service Penetrations

If an element is intended to provide fire separation (i.e. it has a requirement for fire resistance in terms of insulation and integrity), then every joint or opening to allow services to pass through the element should be adequately protected by sealing of fire-stopping so that the fire resistance of the element is not impaired.

Section 3.4 of TGD to Part B of the Building Regulations, and Section 3.7 of TGD to Part B Volume 2 of the Building Regulations provide guidance on the methods of protection of openings and fire stopping.

It is essential that both the designer and the specialist contractor are fully conversant with the fire protection requirements for pipe, cable and service penetrations. The fire stopping is inspected by the Metal Frame Construction site manager and recorded in the Metal Frame Construction quality control file for that site – the fire stopping must be installed correctly before Metal Frame Construction Ltd will issue the Certificate for the building.

2.6 DELIVERY, STORAGE AND SITE HANDLING

2.6.1 Delivery of Panels

Frame panels are transported vertically on stillages or similar sized panels can be flat packed horizontally and transported to site. Where lifting points are required, they are located, designed and certified by the Structural Engineer, taking into account the unit weight and dimensions and the distance of lift required. They will conform to the requirements of the Safety, Health and Welfare at Work Act 2005 and the Safety, Health and Welfare at Work (Construction) Regulations 2013. All off-loading and erection should be in accordance with the Metal Frame Construction Method Statement and erection procedures. Erection tools should be of suitable quality to avoid surface contamination. Smaller panels may be manually manoeuvred into position.

All lifting shall be carried out by competent personnel in accordance with the Metal Frame Construction Erection Manual and site-specific safety statement. Care is needed to avoid scratching the surface of any exposed steel frame members.

The use of protective gloves when handling the LGS panels is necessary, as steel members formed from cut or sheared sheet can have sharp edges and care should be taken when handled, to avoid injury. The exposed steel frames members must be kept out of contact with dry cement and lime.

Frames must be stored on a dry, clean and level base with a suitable packing to prevent damage and must not be dropped or allowed to rest on projecting objects.

Flooring and other ancillary items such as insulation and fire stops must also be kept dry and stored on a firm level base.

2.6.2 Traceability

The Metal Frame Construction System uses a specifically designed quality-controlled system which ensures full traceability can be achieved between design, production and site assembly.

Steel coils delivered to the factory are labelled with a coil identification number. When the coil is loaded on the roll forming machine, this number is recorded which ensures panels produced can be traced to individual coils of steel.

Each assembly drawing contains a unique panel identification number. This allows for ease of assembly for the assemblers. Each panel is labelled with a unique identification sticker when assembly is complete. When each panel is completed, the assembly drawing is signed by the assembler and placed in the project record file.

2.6.3 Typical Material List Supplied to Site

With each customised delivery to site, a comprehensive bill of materials is supplied. This bill of materials gives a detailed list of all components delivered to site to complete the installation of the steel frame building. All panels are individually numbered using the pre-marking system during production to correspond with the erection drawings supplied with the bill of materials. This pre-marking system gives the advantages of both speed and accuracy during assembly and erection on site.

2.6.4 Responsibilities

Prior to the commencement of the contract, the responsibilities are determined and agreed between Metal Frame Construction Ltd and the main contractor. Construction of the foundations,

ground floor slab or podium slab must be within the tolerances specified by Metal Frame Construction. Once the floor slab is within the tolerance range, erection of the Metal Frame Construction Steel Frame Building System can commence.

When the panels are completely erected brick/block laying trades or cladding can commence. The provision of the site-specific fall arrest system to wall plate level is to be agreed between Metal Frame Construction Ltd and the Main Contractor before commencement of the project on site. Metal Frame Construction Ltd also provide the Main Contractor with project specific building details on the construction of their steel frame system.

2.7 INSTALLATION

2.7.1 General

Installation is carried out in accordance with the requirements of this Certificate and all relevant codes of building practice, regulatory Health & Safety requirements and the manufacturer's instructions contained in the Metal Frame Construction Installation Manual, a copy of which must be available on each site. Site erection must only be carried out by a Metal Frame Construction approved installer or a specialist sub-contractor under the supervision of Metal Frame Construction Ltd and in accordance with the Metal Frame Construction Installation Manual.

Installers are approved once they have undergone on-site training, understand the fundamental structural principles of the system, fire stopping/cavity barrier requirements, tolerances, importance of weathering, storage and handling of the panels and all other relevant information. Installers should have installed panels under the guidance of a qualified installer and have a signed record of this training. All off-loading and erection should be in accordance with the Metal Frame Construction Method Statement and erection procedures. Care must be taken to avoid any damage to the steel frame components during lifting, transportation and installation.

All structural connections to the foundation must be installed in accordance with the structural design details, independently checked by qualified members of the installation team and formally recorded on the Metal Frame Construction site quality control records.

It should be noted that the DPC is penetrated with the holding down bolts for the system however, the DPM and radon barrier (which often acts as the DPM) is not penetrated. As the DPC is installed as an element of good practice, as opposed to an essential construction element,

there is no risk to the system if the holding down bolts penetrates the DPC.

2.7.2 Site Supervision

The approved installation contractors are subject to supervision by a Metal Frame Construction Site Manager. Typically, the Metal Frame Construction Site Manager will agree a schedule of inspections with the erection contractor. The supervisor of the erection crew is responsible for the quality and productivity of work carried out by the erection crew. The erection supervisor reports directly to the Metal Frame Construction Site Manager to ensure all work follows the requirements of the design drawings and the requirements of Metal Frame Construction Structural certification for the building.

Metal Frame Construction Ltd employ a full-time site manager who works very closely with the erection supervisor, and the main contractor who is responsible for providing the concrete substructure. The Main Contractor is responsible for ensuring all concrete slabs are within the engineer's specified tolerances before panels are installed on site. No panels are installed until the Metal Frame Construction Site Manager approves the concrete base that the panels are being fixed to. All fixings and brackets between panels are visually inspected and recorded on the assembly quality control sheet for structural connections.

Each building has its own quality control sheet for structural connections, which is kept on site by the Metal Frame Construction Site Manager. All fixings and brackets between panels are visually inspected, periodically photographed and recorded in the quality control file. The Site Manager also inspects the fire stopping and cavity closing of panels, and records of the fire stopping are recorded by Metal Frame Construction Ltd.

Any defects noted are recorded, photographed where possible and notified in writing to the erection supervisor. The site manager will inspect and approve the remediation before work can proceed.

The approved steel frame erection contractors are subject to continuous supervision by the Metal Frame Construction Site Manager. The following checklist is provided to offer guidance to clients who intend to carry out their own additional site supervision. This non-exhaustive list of items is of a general nature and is in addition to all other building requirements.

- All components delivered to site comply with the Bill of Materials.
- Components are not damaged and are properly pre-marked for erection.

- The substructure is set out accurately and level within the tolerance specified by Metal Frame Construction before the wall panels are positioned.
- The steel frame should not be erected unless any inaccuracies in the floor slab have been corrected.
- The ground floor layout is properly marked out.
- DPC and DPM are correctly installed in accordance with BS 8102^[8].
- DPC course is laid under all ground floor panels, as a good practice measure between steel and concrete, for both internal and external walls.
- Panels are in line and plumb and in accordance with the Metal Frame Construction panel layout.
- Rooms are checked for squareness.
- All ground floor steel frame panels are correctly anchored into position (penetrating the DPC but not penetrating the DPM) in accordance with the erection drawings.
- All insulated wall panels are free from damage after erection.
- All horizontal and vertical joints are correctly detailed.
- All bottom tracks are free of construction debris.
- Wall ties are correctly spaced and positioned.
- Joints in floor decking occur on the centre line of the joists and all T&G joints run perpendicular to the floor trusses/C-joists. Decking sheet joints must be staggered.
- If floor decking is exposed to weather for prolonged periods, then it will need to be protected with a weatherproof cover.
- Floor decking is screwed at the correct centres.
- Grommets are installed where necessary in-service holes as per Metal Frame Construction drawings.
- All bracing is properly tensioned.
- Check for requirement of web stiffeners when floor truss/joists are continuous over internal load bearing support walls against Engineers drawings.
- Cavity barriers and fire stops are installed as specified and in accordance with the Building Regulations 1997 to 2023.
- Roof trusses are installed plumb and as per layout.
- Roof bracing installed where required.
- Where galvanised steel section is cut or where any damage occurs to the steel frame a coat of zinc rich paint or galvanised spray is applied to exposed surfaces.
- All fasteners supplied or approved by Metal Frame Construction Ltd.
- No modification i.e. cutting of the steelwork is allowed without prior written permission from the Metal Frame Construction Chartered Structural Engineer.

- Always maintain a minimum 40mm between the two leaves of the party wall.

2.8 INFILL PANEL INSTALLATION

Metal Frame Construction structural steel frame infill panels can be designed for building in two ways:

1. Made to Measure: Metal Frame Construction Site Manager takes actual site measurements of the existing structural frame and design panels to suit.
2. Designed Off Drawings: Metal Frame Construction design panels from the construction drawings with a built-in allowance for site tolerance.

The Metal Frame Construction structural steel frame infill panels are installed on a clean structural slab which has a level tolerance of $\pm 5\text{mm}$. Metal Frame Construction Ltd approved installers install the panels.

For infill panels the bottom track of the structural infill panel is secured to the slab with holding down bolts at the specified locations identified on the Metal Frame Construction drawings. For infill panels, brackets with a deflection allowance will allow the studs to face fix to the superstructure in question.

Metal Frame Construction infill panels are designed to resist lateral loads only to the required deflection limit depending on the façade finish. It is critical that no permanent or variable loading from the superstructure is transferred into the infill panels. Infill panels can be designed and detail to transfer horizontal loads, satisfactorily into the primary structure, while incorporating a soft joint which will allow vertical deflection of the primary structure to occur but will not transfer vertical load into the infill panels.

All vertical and horizontal cavity closing/fire stopping is carried out in accordance with the project specific fire strategy drawings.

2.8.1 Infill Panel Structural Design

The steel panel studs within the infill panel frame are designed to resist wind loading due to the action of wind on the building's cladding. The infill panels are not designed for vertical loads to be transferred to them. The Metal Frame Construction Infill panel can only be used within framed buildings that possess their own independent lateral stability systems and as a result a soft joint is incorporated to ensure that no load transfer occurs.

The design of the superstructure is to be the responsibility of the Clients' Structural Engineer. Before carrying out this design, the Clients Engineer will need to liaise with Metal Frame

Construction Structural Engineer, who will provide the following information:

- The permissible deflection of the primary structure to ensure the steel frame infill panels are allowed to remain within the deflection limits set out by the design.

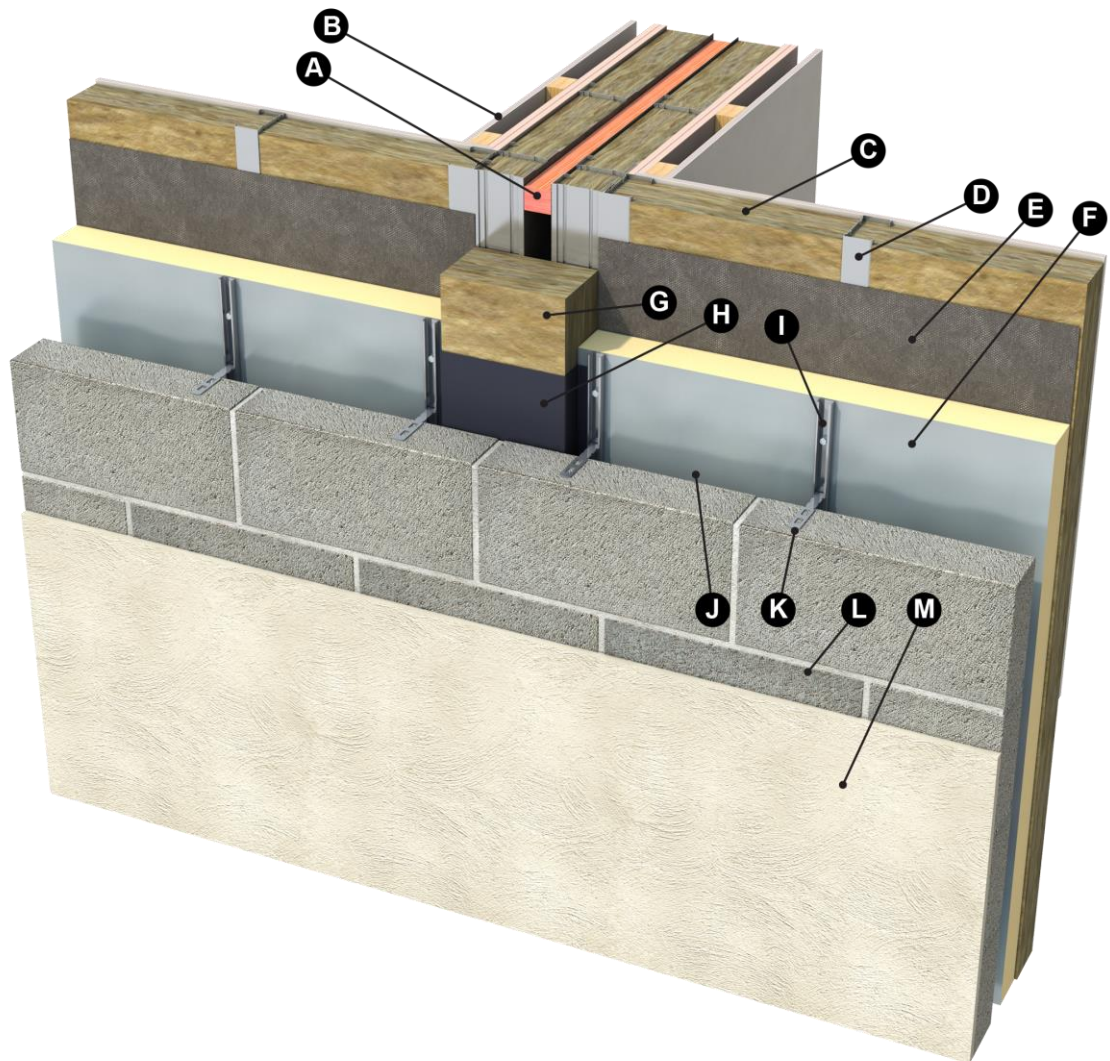

- | | |
|---|--|
| A - Fire Stop at Floor Level | H - DPC |
| B - Plasterboard to Specification | I - MFC Stainless Steel Block/Brick Channel |
| C - Stone Mineral Wool Insulation to specification | J - Cavity |
| D - MFC Steel Stud | K - MFC Stainless Steel Block/Brick Tie |
| E - Air and Vapour Control Layer (AVCL) | L - 100mm External Block/Brick Wall |
| F - PIR Insulation to Specification | M - 20mm Plaster |
| G - Stone Mineral Wool Insulation Cavity Barrier | |

Figure 2: Separating Wall Junction with External Block Wall (External View)

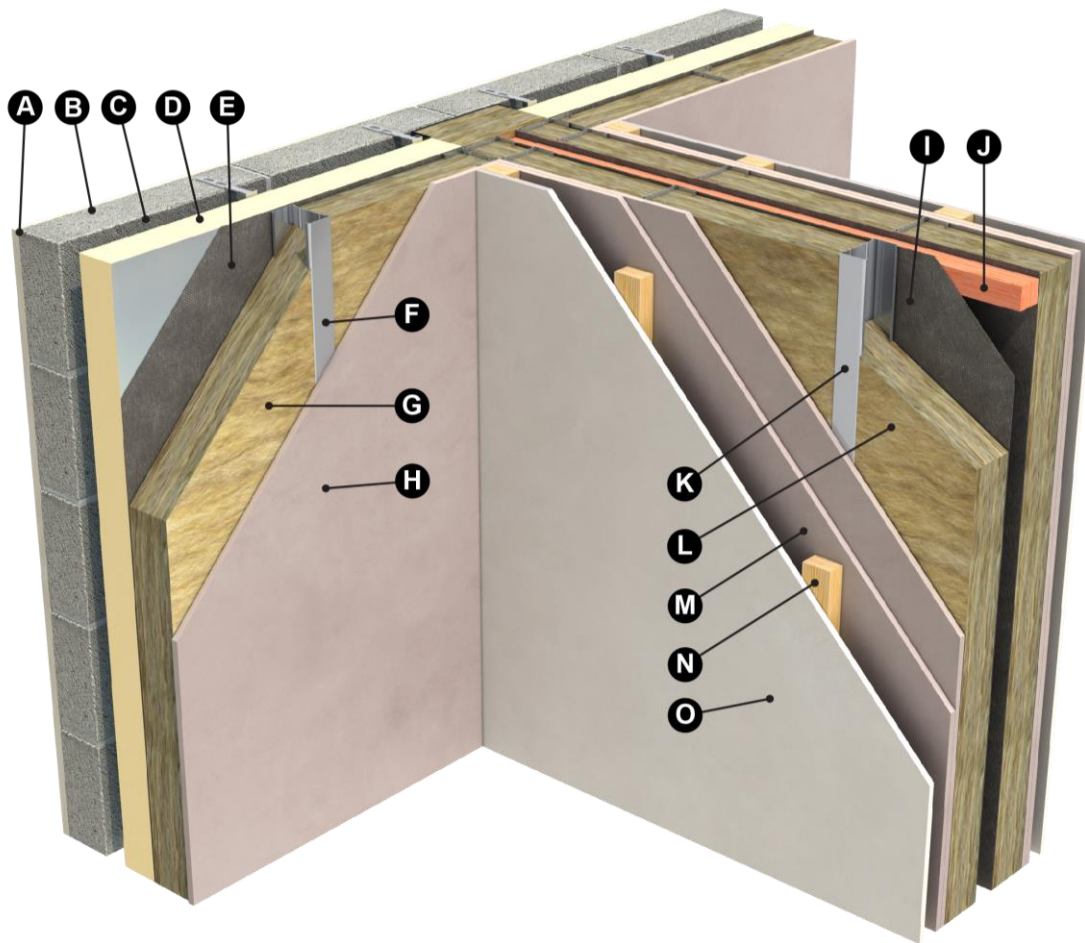

A - 20mm Plaster

B - 100mm External Block/Brick Wall

C - Cavity

D - PIR Insulation to Specification

E - Air and Vapour Control Layer (AVCL)

F - MFC Steel Stud

G - Stone Mineral Wool Insulation
to specification

H - Plasterboard to Specification

I - Airtightness Membrane

J - Fire Stop at Floor Level

K - MFC Steel Stud

L - Stone Mineral Wool Insulation
to specification

M - 2no. 15mm Type F Plasterboard

N - Timber Battens

O - 1no Layer of 12.5mm Type A
Plasterboard

Figure 3: Separating Wall Junction with External Block Wall (Internal View)

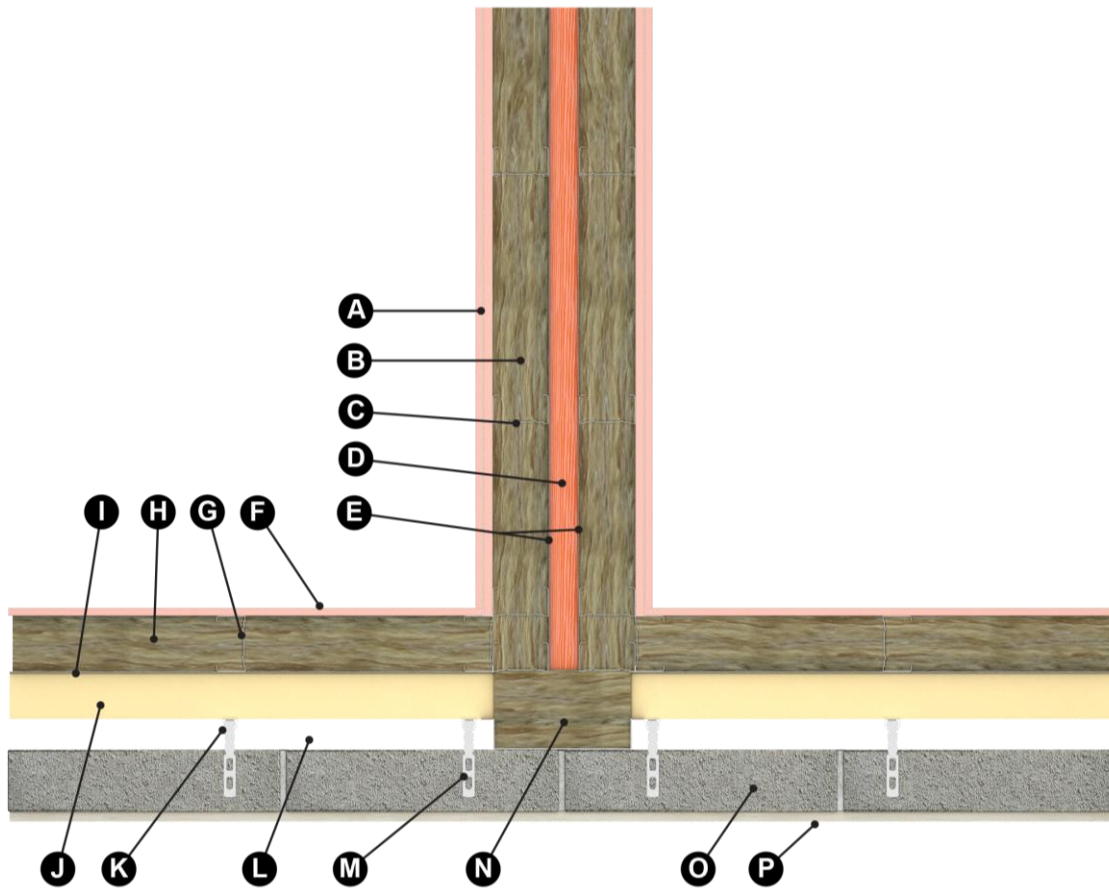

A - 2no.15mm Type F Plasterboard

B - Stone Mineral Wool Insulation to specification

C - MFC Steel Stud

D - Fire Stop at Floor Level

E - Airtightness Membrane

F - Plasterboard to Specification

G - MFC Steel Stud

H - Stone Mineral Wool Insulation to specification

I - Air and Vapour Control Layer (AVCL)

J - PIR Insulation to Specification

K - MFC Stainless Steel Block/Brick Channel

L - Cavity

M - MFC Stainless Steel Block/Brick Tie

N - Stone Mineral Wool Insulation Cavity Barrier & DPC to specification

O - 100mm External Block/Brick Wall

P - 20mm Plaster

Figure 4: Separating Wall Junction with External Wall (Plan View)

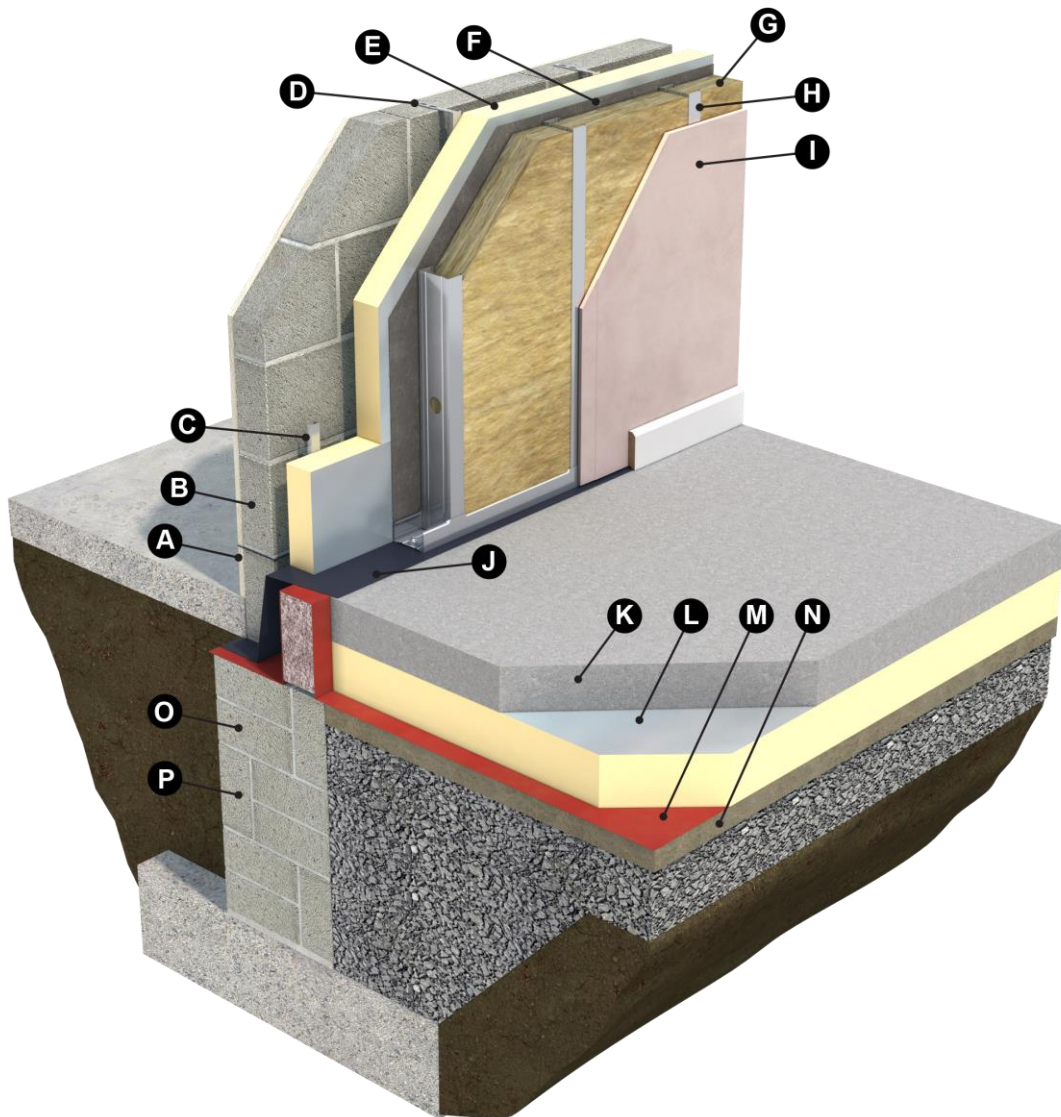

- | | |
|--|-------------------------------------|
| A - 20mm Plaster | I - Plasterboard to Specification |
| B - 100mm External Block/Brick Wall | J - DPC |
| C - MFC Stainless Steel Block/Brick Channel | K - Concrete Slab |
| D - MFC Stainless Steel Block/Brick Tie | L - PIR Insulation to Specification |
| E - PIR Insulation to Specification | M - Radon Barrier |
| F - Air and vapour control layer (AVCL) | N - Sand Binding to Specification |
| G - Stone Mineral Wool Insulation to specification | O - Thermal Block |
| H - MFC Steel Stud | P - Concrete Block |

Figure 5: External Wall to Foundation Detail

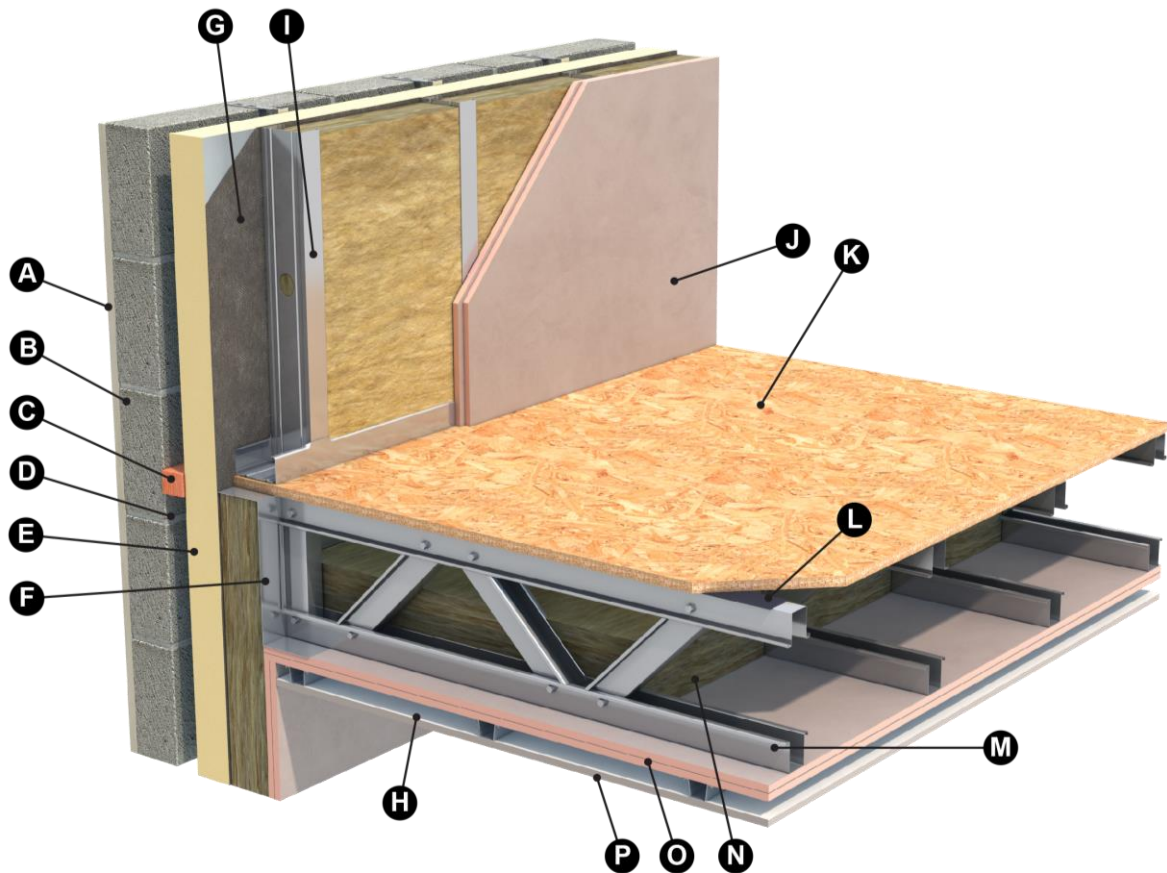

- | | |
|--|---|
| A - 20mm Plaster | J - 2no. Layers of 12.5mm Type F Plasterboard |
| B - 100mm External Block/Brick Wall | K - 18mm OSB3 |
| C - Cavity Barrier | L - Acoustic Barrier |
| D - Cavity | M - MFC lattice Joists |
| E - PIR Insulation to Specification | N - Stone Mineral Wool Insulation to specification |
| F - MFC Z Hanger | O - 2no. Layers of 12.5mm Type F Plasterboard |
| G - Air and vapour control layer (AVCL) | P - Plasterboard to Specification |
| H - Service Cavity | |
| I - MFC Steel Stud | |

Figure 6: External Wall to Compartment Floor Junction Detail

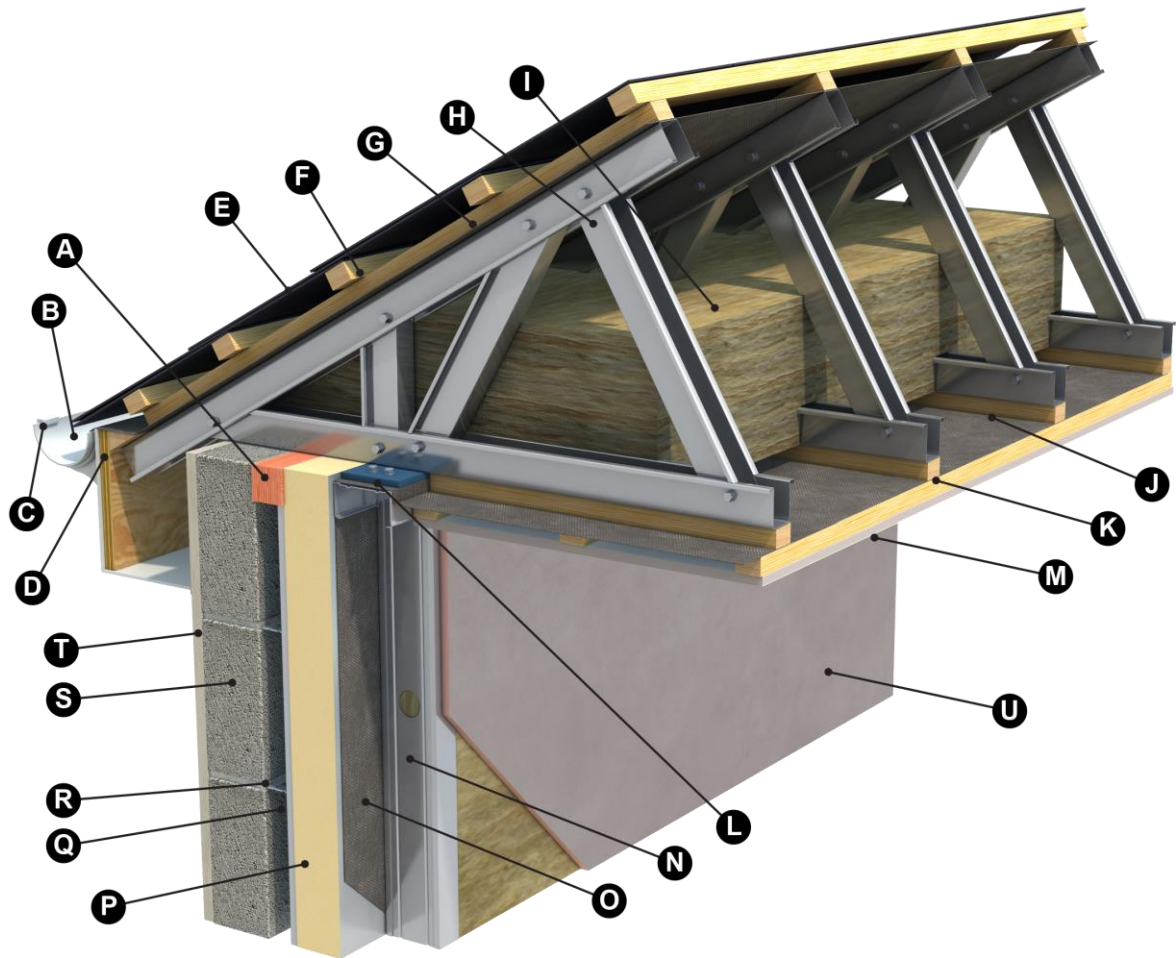

A - Cavity Close

B - Gutter

C - Gutter Bracket

D - Top Board

E - Roof Slate Tile

F - Timber Battens

G - Roofing Felt

H - MFC Steel Trusses

I - Stone Mineral Wool Insulation
to specification

J - Air and Vapour Control Layer (AVCL)

K - Timber Battens

L - Thermal Break

M - Plasterboard to Ceiling to Specification

N - MFC Steel Stud

O - Air and Vapour Control Layer (AVCL)

P - PIR Insulation to Specification

Q - MFC Stainless Steel Block/Brick
Channel

R - MFC Stainless Steel Block/Brick
Tie

S - 100mm External Block/Brick Wall

T - 20mm Plaster

U - Plasterboard to specification

Figure 7: Light Gauge Steel Truss Cold Roof Junction to External Wall Detail

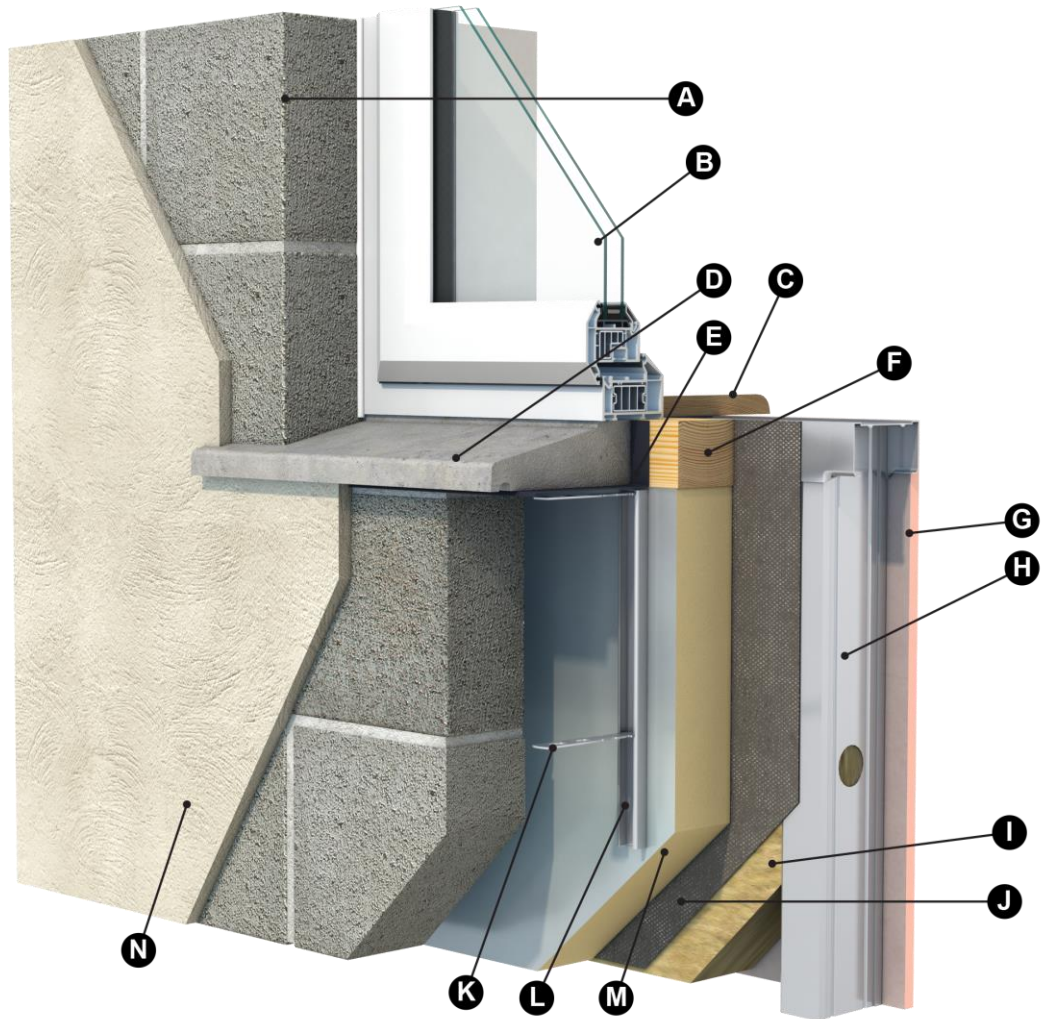

A - 100mm External Block/Brick Wall

B - Window

C - Window Board

D - Window Cill

E - DPC

F - Treated Timber Batten

G - Plasterboard to Specification

H - MFC Steel Stud

I - Stone Mineral Wool Insulation to specification

J - Air and Vapour Control Layer (AVCL)

K - MFC Stainless Steel Block/Brick Tie

L - MFC Stainless Steel Block/Brick Channel

M - PIR Insulation to Specification

N - 20mm Plaster

Figure 8: Window Sill Detail

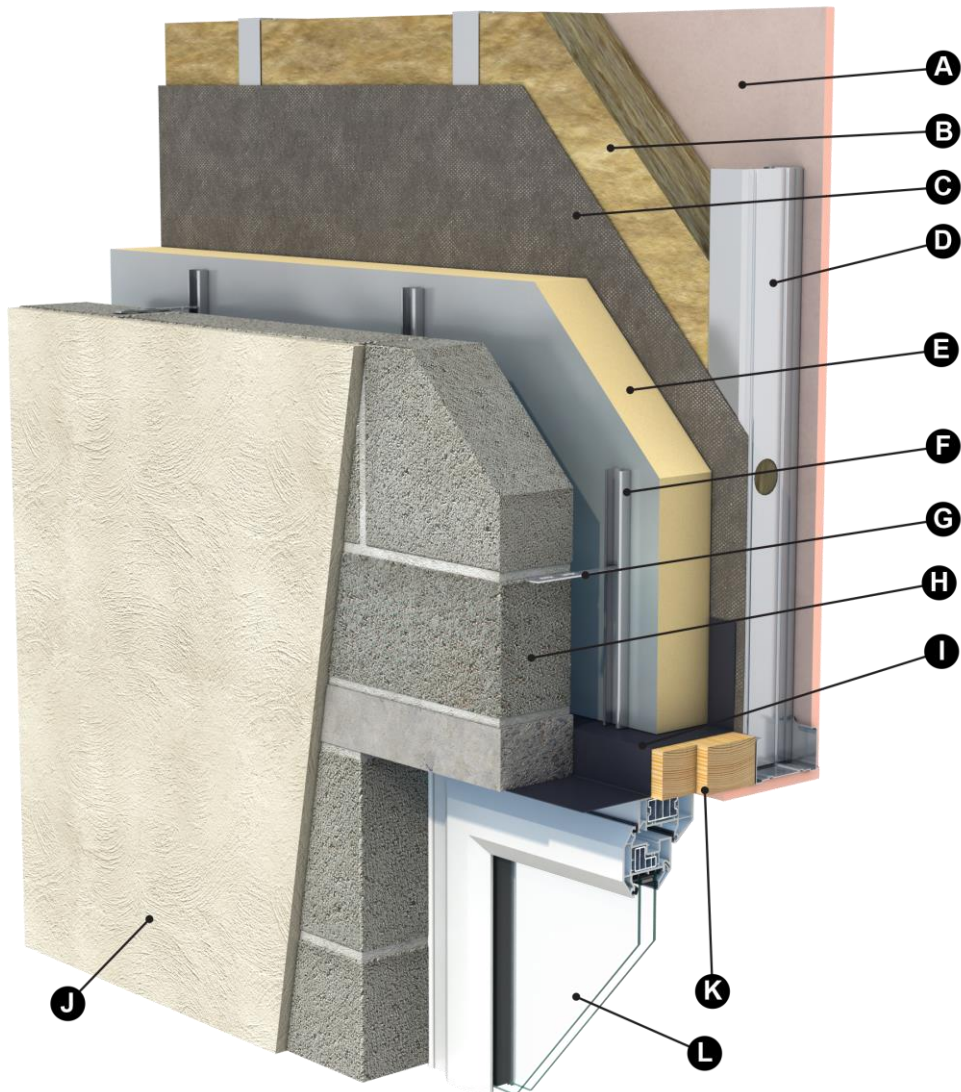

A - Plasterboard to Specification

B - Stone Mineral Wool Insulation to specification

C - Air and Vapour Control Layer (AVCL)

D - MFC Steel Stud

E - PIR Insulation to Specification

F - MFC Stainless Steel Block/Brick Channel

G - MFC Stainless Steel Block/Brick Tie

H - 100mm External Block/Brick Wall

I - DPC

J - 20mm Plaster

K - Treated Timber Batten

L - Window

Figure 9: Window Head Detail

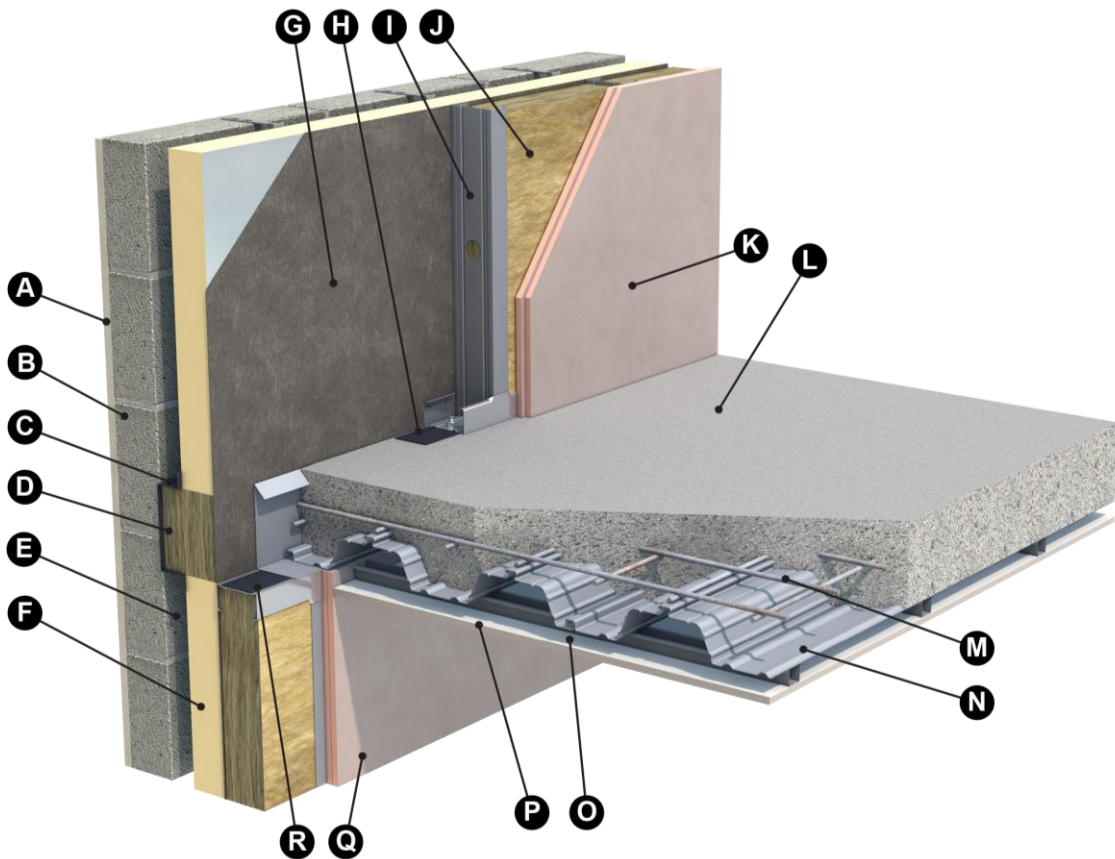

- | | |
|---|---|
| A - 20mm Plaster | K - 2no. Layers of 12.5mm Type F Plasterboard |
| B - 100mm External Block/Brick Wall | L - Concrete to specification A393 Mesh |
| C - DPC | M - A393 Mesh |
| D - Cavity Barrier | N - Profiled metal floor deck to specification |
| E - Cavity | O - Service Cavity |
| F - PIR Insulation to Specification | P - Plasterboard to Specification |
| G - Air and Vapour Control Layer (AVCL) | Q - 2no. Layers of 12.5mm Type F Plasterboard |
| H - Isolation Strip | R - Isolation Strip |
| I - MFC Steel Stud | |
| J - Stone Mineral Wool Insulation to specification | |

Figure 10: Composite Concrete Metal Deck to External Wall Junction Detail

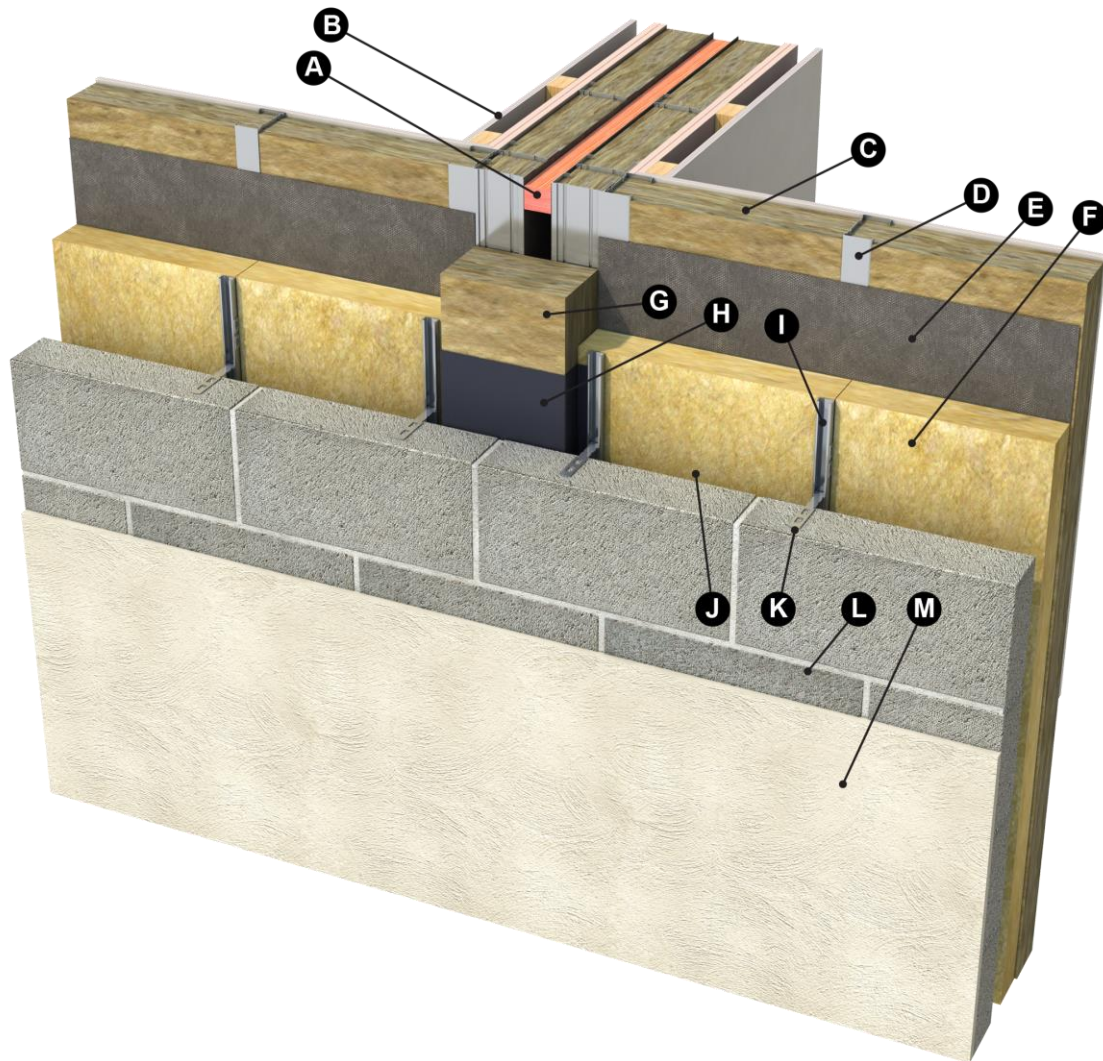

- | | |
|---|--|
| A - Fire Stop at Floor Level | H - DPC |
| B - Plasterboard to Specification | I - MFC Stainless Steel Block/Brick Channel |
| C - Stone Mineral Wool Insulation to specification | J - Cavity |
| D - MFC Steel Stud | K - MFC Stainless Steel Block/Brick Tie |
| E - Air and Vapour Control Layer (AVCL) | L - 100mm External Block/Brick Wall |
| F - Duo Slab Insulation to Specification | M - 20mm Plaster |
| G - Stone Mineral Wool Insulation Cavity Barrier | |

Figure 11: Non-Combustible External Wall Junction with Separating Wall Detail (External View)

3.1 STRENGTH AND STABILITY

3.1.1 Certificate of Structural Compliance

The Metal Frame Construction Steel Frame Building System is intended for use where the Client's Design Team/Architect's drawings are available and satisfy the Building Regulations 1997 to 2023. The Architectural and Engineering design team of the Client are responsible for the architectural drawings and overall building design to comply with the Building Regulations. Metal Frame Construction Ltd using an experienced Chartered Structural Engineer, are responsible for the structural design of the Metal Frame Construction Steel Frame Building System.

Building Control (Amendment) Regulations (S.I. 9) of 2014 (BCAR) came into action from 1st March 2014. The Metal Frame Construction system certification will typically be supplied as a sub-contractor role under BCAR projects which will require Metal Frame Construction Ltd to furnish the relevant ancillary certification per project. The appointed person within Metal Frame Construction will liaise with the Assigned Certifier (AC)/Employers Representative (ER) and the Design Certifier where applicable, furnishing the relevant Commencement Notice data, within the timeframe requested, along with an inspection notification framework summary and completion ancillary certificate as and when required.

It is imperative that all design team members are clear in relation to what elements of the project Metal Frame Construction Ltd are responsible for and what the ancillary certificate relates to.

Buildings constructed using the Metal Frame Construction Steel Frame Building System shall be certified by a competent, Chartered Engineer as being in accordance with Part A of the Building Regulations 1997 to 2023.

3.1.2 Superstructure Design

The Metal Frame Construction Building System can be designed to comply with the requirements of Part A of the Building Regulations 1997 to 2023 regarding the design to avoid disproportionate collapse.

The structural assessment of the Metal Frame Construction Building System shall be site and project specific and a Structural Design Engineer suitably experienced in this type of structure shall undertake the structural engineering of every building element designed by Metal Frame Construction Ltd. In accordance with IS EN 1990^[15], a DSL2 (Design Supervision Level)

should be employed to check the design in line with good practice.

This structural design certificate should cover the adequacy of all the cold formed and hot rolled elements within the structure in question which Metal Frame Construction Ltd supply. It should also address the dimensions and thickness of each element and member making up the steel frame superstructure and assess the suitability of the interface between the superstructure and the external cladding (brick, block or NSAI Agrément approved). The structural certificate of compliance must also confirm that there is sufficient uplift resistance and that there is adequate racking and load bearing capacity to either side of any opening to ensure the stability of the wall. Dwellings designed and constructed in accordance with this Certificate will have adequate strength and stability as per the building codes and standards. Metal Frame Construction Ltd also undertake the structural design of every building constructed with the Steel Concrete Composite Deck and the certificate should address this also as required.

3.1.3 Substructure Design

The design of the building's substructure is outside the scope of this certificate. The design of the substructure is to be the responsibility of the Client's Engineer. The Engineer will need to be a suitably qualified Chartered Structural Engineer and the design will need to be in accordance with the relevant codes and standards, i.e. Foundation's must be designed in accordance with IS EN 1997-1^[28]. Metal Frame Construction Ltd's Engineer will be responsible for undertaking a load take down for the structure and providing this information to the Client's Engineer for use in the design of the substructure. The Metal Frame Construction Ltd's Engineer will also need to provide the Client's Engineer with the permissible deflection of the ground floor slab under the Metal Frame Construction Ltd's Steel Frame line loads and podium slab level loading.

3.1.4 Design Loads

The design of a typical building has been examined by the NSAI Agrément and demonstrates compliance with the following Codes of Practice. In general, the wall panels, floor trusses and roof truss are designed in accordance with:

- IS EN 1993-1-1+NA^[22] and timber roof trusses to IS EN 1995-1-1+NA Eurocode 5^[26];
- IS EN 1991-1-1+NA Eurocode 1^[16];
- IS EN 1991-1-4+NA Eurocode 1^[17];

- IS EN 1991-1-3+NA Eurocode 1^[18];

Design wind and snow loads should be based on Diagrams 1 and 14 of TGD to Part A of the Building Regulations 1997 to 2023.

Non-load bearing partitions and walls are designed in conformance with the criteria set out in BS 5234-1^[30] and IS EN 10143^[31]. Typical design loads, in the absence of client specified, project specific loads, are:

- Imposed load on floor of 1.5kN/m² plus an allowance of 0.5kN/m² for internal partitions.
- Roof imposed loads of 0.60kN/m² with an allowance of 0.25kN/m² distributed load over a loft space with access, along with a concentrated load (point load) of 0.9kN i.e. water tank.
- Wind loads based on IS EN 1991-1-4+NA^[17].

Greater loads can be accommodated by request.

3.1.5 Steel Concrete Composite Deck Design

Metal Frame Construction Structural Engineer is responsible for the structural design of the steel composite concrete decks. The Metal Frame Construction Engineer is also responsible for the design of the propping of this deck where propping is required, and the design of the procedure to remove the propping where propping is required. A safe system of work for the propping of the slab must be agreed between the Clients Engineer and the Metal Frame Construction Structural Engineer and needs to be strictly adhered too on site.

The profiled steel deck and all accessories such as slab edge trim, restraint strap and closures etc. are installed by Metal Frame Construction trained erectors. All propping and reinforcement is to be done to Metal Frame Construction propping and deck reinforcement plans. The execution of the propping and reinforcement plan is the responsibility of the main contractor or Metal Frame Construction installers if included in their scope of works.

The Metal Frame Construction Structural Engineer and Metal Frame Construction Site Manager inspect the installation of all decks prior to pouring of concrete to ensure the supporting structure, including temporary props, all reinforcement, screw fixings, shutters and straps are installed correctly. The metal deck is designed to bear on to the top of the head track and must have a minimum end bearing suitable to the profile being used before it is fixed. Steel reinforcement required by a specific design is placed into position as required.

The concrete mix must be specified in accordance with project specific design to IS EN 1992-1-1^[20]

Eurocode 2 and should be supplied and manufactured in accordance with IS EN 206^[7] and National Annex amended 2021. The concrete must be supplied and laid in accordance with BS EN 1992-1-1^[20] Eurocode 2. The concrete should be dispensed across the decking to avoid 'heaping' and the surface levelled in accordance with the decking manufacturer's recommendations.

The results of concrete cube compressive test must be supplied to the Metal Frame Construction Structural Engineer to ensure that the actual concrete strength attained, achieve the strengths required.

Concrete run-off and spillage should be minimised and build-up of debris in base tracks should be avoided. In cold weather the concrete should be protected from the effects of frost and rain until adequately cured. Props, where required to be used, are not to be removed until concrete has reached the required strength or passed the curing period. The approval that the concrete has reached its required strength is the responsibility of the Contractor who poured the concrete. Only once this approval is received, will the Metal Frame Construction Structural Engineer give approval to remove the props under the floor.

3.1.6 Structural Testing

Where it is required, structural testing has been used to verify the relevant aspects of the structure where the design falls outside the scope of IS EN 1993-1-1+NA^[22].

3.1.7 Wind Load

Buildings designed in accordance with the Metal Frame Construction Building System Design Manual will have adequate resistance to wind load in areas as outlined in Figure 1 (a) Map of wind speeds (v) in m/s of TGD to Part A of the Building Regulations 1997 to 2023. For very exposed sites on hills above the general level of the surrounding terrain, the system can be specifically designed to meet the requirements as defined in IS EN 1991-1-4+NA^[17]. The system can be designed to be used in all locations in Ireland.

3.2 STRUCTURAL FIRE SAFETY

Any dampers, ductwork, and sealing of gaps formed by services that pass through the compartment walls and floors will involve suitably tested systems which have included appropriate fire resistance testing for the required time duration. Details around penetrations and openings such as doors and windows shall avoid any excessive heat ingress into the wall cavities.

All materials such as cavity barriers and fire stops, used in the construction comply with IS EN

13501-1^[44]. They shall be detailed as described in Section 2.5.6 (of this Certificate) and as specified in the Metal Frame Construction fire stopping details in line with the supporting documents to the Building Regulations 1997 to 2023.

Any compartment or separating wall providing fire compartmentation shall be carried up through any roof space and brought up to the underside of the roof cladding to provide adequate fire stopping. No services can pass through a separating wall. Services are permitted within all internal and external loadbearing and non-loadbearing walls of the Metal Frame Construction Steel Frame Building System provided the wall is not a separating wall.

All fire testing on the Metal Frame Construction walls has been carried out with services penetrations in the wall to accurately test the system.

3.2.1 Structural Fire Safety; Purpose Groups of TGD B Vol 2 2017, Dwellings.

The buildings in purpose class 1(a), 1(b) & 1(d) are covered under TGD B Fire Safety Dwelling Houses Volume 2 to Part B of the Building Regulations 1997 to 2023. Under this revision buildings designed in accordance with the Eurocodes require the structural fire resistance performance specified, to be achieved in accordance with European test methods. The European tests required to be used are IS EN 1364-1:2015^[33], IS EN 1365-1:2012^[34], and IS EN 1365-2^[35].

The load-bearing and non-loadbearing elements of the above purpose classes have a fire resistance performance in accordance with the required European test method.

3.2.2 Structural Fire Safety; Purpose Groups of TGD B (2020 reprint).

The other Purpose Classes (1(c), 2(a), 2(b), 3, 4(a) and 5 to which this Certificate relates are covered under TGD B (2020 reprint) to Part B of the Building Regulations 1997 to 2023.

The fire resistance performances of elements of non-loadbearing and loadbearing structure are given in Table 4 as a combination of IS EN 1364-1:2015^[33], IS EN 1365-1^[34] and IS EN 1365:2^[35]. Table 4 contains fire resistance tests to 30, 60 and 90 minutes.

3.3 IMPACT RESISTANCE

The interaction of components is such that, if subjected to exceptional impacts causing local failure, the overall stability of the structure will not be dangerously impaired.

4.1 BEHAVIOUR IN RELATION TO FIRE

4.1.1 Fire Resistance

Fire tests show that buildings constructed using the Metal Frame Construction Steel Frame Building System can meet the Building Regulation requirements in relation to fire resistance as shown in Table 4. The fire tests have demonstrated the ability of the Metal Frame Construction Steel Frame Building System to withstand severe fire exposure for the period required for compliance with the Building Regulations in terms of fire performance. Tests have been conducted by Metal Frame Construction Ltd to meet fire test requirements IS EN 1365-1^[34] and IS EN 1365-2^[35]. The fire resistance required is dependent upon the purpose class and height of the building being designed and constructed.

The Metal Frame Construction Steel Frame Building System must be designed with the required boarding specification to meet the minimum requirements specific to the purpose group; for purpose groups 1(a), 1(b) & 1(d), Table A1 of TGD B Volume 2 (2017) to Part B of the Building Regulations 1997 to 2023, applies. For purpose classes, 1(c), 2(a), 2(b), 3, 4(a) and 5, Table A2 of TGD B (2020 reprint) to Part B of the Building Regulations 1997 to 2023 applies, and any other building specific structural fire performance requirements. Table 4 of this Certificate provides a table of fire resistance performances which provide a variety of boarding specifications and their associated fire resistance performance that will have its stability maintained for the minimum required period in the event of fire.

There shall be two leaves in a steel frame separating wall with a minimum of 40mm clear cavity distance between the two leaves maintained throughout the cavity. Services shall not be placed in the cavity or penetrate the wall linings of separating walls. Where services are required, an additional service cavity shall be provided so that the integrity of the fire lining is maintained.

Services shall not be placed in the cavity of a compartment wall. Where services are required to penetrate a compartment wall, all such penetrations shall be kept to a minimum and shall be fire stopped. Where services (e.g. light switches and sockets) are placed on a compartment wall, a service cavity shall be provided so that the integrity of the fire lining is maintained. Where a compartment wall has two separate leaves, a minimum of 40mm clear

distance shall be maintained throughout the wall cavity.

Accommodation of services in Compartment Walls/Floors and Separating Walls must be in accordance with Section 3.5.4.1 of TGD B 2017 Volume 2 of Building Regulations 1997 to 2023 for purpose class 1(a), 1(b) & 1(d) and in accordance with Section 3.2.5.7 and 3.4 of TGD B (2020 reprint) of the Building Regulations 1997 to 2023 for all other purpose classes to which this certificate applies. Services may be surface mounted or accommodated in service ducts or within service cavities created external to the linings of the fire-resistant compartment walls or floors.

The Metal Frame Construction Steel Frame Building System can be designed to accommodate sub-divided fire resisting construction in accordance with a Fire Safety Certificate where it is necessary to inhibit the spread of fire within the building.

The building details of the system shall incorporate suitable cavity barriers and fire stops to satisfy the requirements for a given purpose group. For purpose groups 1(a), 1(b) & 1(d), TGD B Volume 2 (2017) applies. For purpose classes, 1(c), 2(a), 2(b), 3, 4(a) and 5 TGD B (2020 reprint) applies.

An apartment, a house in a terrace and a semi-detached house are treated as separate buildings and therefore must be separated by a separating wall (party wall), as shown in both TGD B 2020 reprint and TGD B Volume 2 to Part B of the Building Regulations 1997 to 2023. Where a window is required to provide an alternative means of escape in a dwelling house or apartment, it must provide an unobstructed opening of at least 0.33m² with a minimum width and height of 450mm. The opening section should be capable of remaining in the position, which provides the minimum clear area. The window should be positioned to comply with TGDs to part B of the Building Regulations 1997 to 2023. Any restrictor fitted on the window, must be easy to operate.

The fire resisting elements of the construction that are specified in Table 4 of this Certificate provide for 30 minutes, 60 minutes and 90 minutes fire resistance for a range of specifications.

4.1.2 Plasterboard Installation

The proper application of plasterboard to the steel frame members is critical for both fire and sound performance. Attention shall be given to proper and practical detailing on the part of the designer and a high standard of workmanship on behalf of the contractor. Plasterboard in addition to all cavity barriers and fire stops on all structural and separating walls must be fully checked on site and signed off by Main Contractor in accordance with project specific construction details. All plasterboard that provides fire resistance to load bearing and non-load bearing elements of structure must conform to the requirements of Type F to IS EN 520:2005 and must be installed in accordance with the specification given in Table 4. If alternative boarding is proposed, then an independent fire test report from an Accredited Fire Testing Laboratory needs to be provided and assessed by a competent Fire Engineer.

4.1.3 Surface Spread of Flame

An external cladding of brick/block has a designated Class 0 surface spread of flame as shown in Table 3. For a more comprehensive list of material and product fire performance ratings, reference should be made to Table A6 of TGD B (2020 reprint) to Part B of the Building Regulations 1997 to 2023 and to Table A5 of TGD B Vol 2, 2017, to Part B of the Building Regulations 1997 to 2023.

Material	Fire Rating (National Class)	Fire Rating (European Class)
Brickwork/Blockwork	Class 0	Class B-s3, d2
Timber Boarding	Class 3	Class D-s2, d2
Internal Plasterboard before decoration	Class 0	Class B-s3, d2
Slates/Tiles	AA	Class BRoof(t4)

Table 3: Surface Spread of Flame Characteristics

4.1.4 Protection of Building

Combustible material e.g. insulation, should be separated from the flue of a masonry chimney by at least 200mm, or at least 40mm from the outer surface of the chimney. Details are given in Section 2 and Diagrams 2 – 6 of TGD to Part J of the Building Regulations 1997 to 2023. The separation from a heating appliance to combustible wall insulation material should be as per Clause 2.5.6 and Diagram 6 of TGD to Part J of the Building Regulations 1997 to 2023. For chimneys, covered by IS EN 1859:2009, separation between this product and the external surface of the chimney is determined in

accordance with Clause 2.5.7 to 2.5.8 and in accordance with Diagram 7 of Part J of the Building Regulations 1997 to 2023.

Combustible material in proximity to a constructional hearth must be protected by 250mm of solid concrete or as detailed in Diagram 8 of TGD to Part J of the Building Regulations 1997 to 2023.

4.1.5 Roof Designation

All tiles or slates used in the roof in conjunction with the system are designated AA in accordance with TGD to Part B of the Building Regulations 1997 to 2023 (see Table A5 of TGD B (2020 reprint) and Table A4 of TGD B Volume 2 for notional designations of roof coverings). Other NSAI Agrément approved roof coverings may also be used with the system under the guidance of the Metal Frame Construction Engineer.

4.1.6 Cavity Barriers

The Metal Frame Construction Steel Frame Building System can incorporate both horizontal and vertical cavity barriers and fire stops to comply with the fire strategy drawings supplied by the Clients Fire Consultant and to satisfy the requirements of Section 3 of TGDs to Part B of the Building Regulations. Additional guidance is contained in BS 9991 & BS 9999. The Main Contractor is responsible for ensuring all fire stopping/cavity closers are installed in accordance with Metal Frame Construction drawings. The Metal Frame Construction offsite site manager will inspect all cavity barriers and fire stops prior to the closing up of the cavities and ceilings and this is recorded in the quality control file for that site – the fire stopping must be installed correctly before Metal Frame Construction will issue the certificate for the building.

4.2 THERMAL INSULATION

The panels are designed as hybrid warm frame system where the LGS sections are located on the warm frame side of the insulation. Some building elements, namely the roof, ground floor, windows and doors may be site and project specific. Therefore, the U-value of these elements must be calculated before overall compliance with Part L of the Building Regulations 1997 to 2023 can be determined. The Metal Frame Construction System can be provided for a wide range of required elemental u-values.

TGD Part L of the Building Regulations 1997 to 2023 directs users to Digest 465 "U-values for light steel construction" published by BRE. A more precise result is obtained by using a numerical method which conforms to IS EN ISO 10211:2007.

Tables 5 to 8 of this Certificate give a range of elemental U-values for Metal Frame Construction external wall with brick outer leaf and a 50mm unventilated cavity. In addition, sample U-value calculations for ground floor slab for a range of perimeter to area (P/A) ratios are also provided. With the appropriate amount of insulation outside of the steel frame, the system meets and exceeds the maximum back-stop elemental U-value requirements of Table 1 of TGD Part L of the Building Regulations 1997 to 2023.

4.2.1 Limiting Thermal Bridging

The linear thermal transmittance ψ -value (Psi-value) describes the heat loss associated with junctions and around openings. The Certificate holder has carried out ψ -value calculations for a range of thermally bridged junctions.

Table 9 of this Certificate gives ψ -value for a range of Metal Frame Construction Steel Framed Building System junctions and their corresponding flanking elemental U-value. When flanking elemental U-values deviate by an aggregated 20% from the target U-values, the ψ -values no longer remain valid and guidance must be sought from the Certificate holder. A full listing of ψ -value calculations, along with the building details on which calculations are based, are contained within the Certificate holder's Technical Manual.

Bridged junctions where thermally modelled in accordance with BRE IP 1/06^[2] and BRE Report BR 497^[3] by NSAI Certified Thermal Modellers.

The Dwelling Energy Assessment Procedure (DEAP) used to produce the Building Energy Rating (BER) for a dwelling takes account of the total effects of thermal bridging through the input of the "y" value, with is a multiplier applied to the total exposed area of the building.

Where limited provisions are made to eliminate any risk of surface condensation or mould growth, the default "y" value of 0.15 should be taken. When all building junctions are demonstrated to be equivalent to or better than the corresponding Acceptable Construction Details (ACD), then the "y" value can be taken as 0.08.

Alternatively, the transmission heat loss coefficient due to thermal bridging (H_{TB}) can be calculated out by summing up the ψ -values for each junction and multiplying by the linear length of each junction. The "y" value is calculated by dividing H_{TB} by the exposed surface area.

' Ψ ' values for other junctions are outside the scope of this certificate should be assessed in accordance with the BRE IP 1/06 and BRE Report

BR 497 in accordance with appendix D of TGD to Part L of the Building Regulations 1997 to 2023.

4.2.2 Internal Surface condensation

As part of the assessment carried out to determine the ψ -values, internal surface temperatures factors (f_{Rsi}) are also checked. When internal surface temperatures are greater than 15°C, best practice will have been adopted to safe guard against the risk of surface condensation occurring under normal occupancy and humidity class levels.

The Metal Frame Construction Steel Frame Building System has been assessed and when detailed in accordance with this Certificate, these thermally bridged junctions comply with the requirements of Section D.2 of Appendix D of TGDs to Part L of the Building Regulations 1997 to 2023.

4.3 VENTILATION

4.3.1 Un-designed Air Infiltration

Air permeability can be measured by means of a pressure test and this is now a mandatory requirement under TGDs to Part L of the Building Regulations 1997 to 2023 to show compliance with the backstop air permeability index of 7 $m^3/(hr.m^2)$ at a pressure differential of 50Pa across the building envelope.

When inputting values into DEAP, the measured air permeability index at a pressure differential of 50Pa across the building envelope is divided by 20 to determine an air permeability value which is more representative of the actual pressure differential across the building envelope under normal conditions.

The procedure for testing is specified in I.S. EN ISO 9972:2015^[36].

The basic or minimum number of air pressure tests for each dwelling type is described in Table 4 of TGD to Part L of the Building Regulations 1997 to 2023. When using this method to demonstrate compliance for a multi-unit development, then the backstop air permeability index of 7 $m^3/(hr.m^2)$ must be entered in DEAP for all untested units. When using air permeability values better than the backstop values of 7 $m^3/(hr.m^2)$, a test must be performed on each unit.

When air permeability values better than 7 $m^3/(hr.m^2)$ are achieved, the guidance given in Section 4.3.2 of this Certificate should be considered.

To enhance the airtightness performance an AVCL can be installed on all external walls and ceiling lines but this must be done at design stage to maximize performance as part of

airtightness strategy and reduce penetrations of the airtightness line for the building. To avoid excessive heat losses due to un-designed air infiltration, it is necessary to install peripheral seals around windows, doors, services, floors, roof and all building junctions which penetrate the envelope of the building component relied upon to perform the air sealing function of the building.

4.3.2 Designed Ventilation

TGD to Part F of the Building Regulations 1997 to 2023 prescribes ventilation requirements to meet needs of occupants within the building. This can be achieved by limiting moisture content of the air within the building so that it does not contribute to condensation and mould growth and to limit the concentration of harmful pollutants in the air within the dwelling.

In addition to ventilation requirements within the dwelling living space, TGD to Part F makes provisions for ventilation requirements in roofs and roof voids above the insulation line. These provisions will allow for the removal of moisture laden air or condensation which may enter the roof structure from the dwelling either through diffusion or exfiltration.

When air permeability values better than $7 \text{ m}^3/(\text{hr.m}^2)$ are achieved, the basic provisions for background ventilators shall be increased as described in Clause 1.2.2.1 of TGD to Part F of the Building Regulations 1997 to 2023.

When continuous mechanical ventilation systems are being considered, low air permeability values will be required for the energy efficient operation of the mechanical systems.

4.4 INTERSTITIAL CONDENSATION

4.4.1 Condensation in Walls

Calculations to BS 5250^[1] have been carried out for all possible wall build ups as covered by this certificate and predict no interstitial condensation within the external wall and pass the risk criteria in IS EN ISO 13788^[37].

It is recommended to provide an AVCL between the steel frame and the PIR insulation to protect against interstitial condensation. In situations where an AVCL is omitted or where the AVCL is to be provided behind the plasterboard, a condensation risk calculation must be provided by the Clients Design Team to assess the build-up proposed, considering the location of the building, the occupancy and purpose class.

4.4.2 Condensation in Roof

In both cold (insulation at ceiling level) and warm (insulation along the slope) roofs, it is recommended that an AVCL is provided on the warm side of the insulation to limit the migration

of moisture laden air from the dwelling, entering the roof structure through diffusion. The AVCL can double as the air tight barrier.

Roof ventilation should be carried out in accordance with TGD Part F of the Building Regulations 1997 to 2023 and the recommendations of BS 5250^[1]. It is important to ensure that the ventilation is not obstructed by roof insulation at eaves level. When roof insulation is packed into the eaves space, proprietary eaves tray may be provided to maintain ventilation at the eaves.

In the case of cold flat roofs, a cross-ventilated void, not less than 50mm deep, between the slab or deck and insulation should be provided in conjunction with the AVCL being provided on the warm side of the insulation. Ventilation openings should be provided to every roof void along two opposite sides of the roof and should be equivalent in area to a continuous opening of not less than 25mm at each side. It should also be noted that the dimensions of the cross-ventilated void and the ventilation depends on the size of the roof.

In the case of warm flat roofs, the risk of surface condensation is dependent on the nature of the supporting structure. With all flat roofs, there is a risk of interstitial condensation forming between the thermal insulation and the waterproof covering. To avoid this risk, an AVCL should be provided immediately above the supporting structure.

In the case of inverted flat roofs, it is essential that the thermal insulation used resists water absorption and is sufficiently load bearing to support the protective finish of ballast, paving or soil.

Table 4: Fire Protection Requirements for Wall, Floor and Ceiling Elements

Type	Element:	Test Standard	Results	Purpose Class
External Loadbearing Walls				
1	LGS C-Studs (90mmx47mmx1.2mm) with 1No. layer 12.5mm Type F plasterboard fixed to the fire side face and 70mm PIR Insulation fixed to the non-fire side with 100mm stone mineral wool insulation between the LGS studs. 2 No. Double Sockets were also fitted on the Fire Side.	IS EN 1365-1: 2012	30 mins from inside	1(a), 1(b), 1(c), 1(d), 2(a), 2(b), 3, 4(a) and 5
2	LGS C-Studs (90mmx47mmx1.2mm) with 2No. layers 12.5mm Type F plasterboard fixed to the fire side face and 2 No. layer 12.5mm Type F plasterboard fixed to the non-fire side with 100mm stone mineral wool insulation between the LGS studs. 2 No. Double Sockets were also fitted on the Fire Side.	IS EN 1365-1:2012	60 mins from exposed side	1(a), 1(b), 1(c), 1(d), 2(a), 2(b), 3, 4(a) and 5
3	LGS C-Studs (90mmx47mmx1.2mm) with 3No. Layers of 12.5mm Type F Plasterboard fixed to the fire side face and 75mm of Rockwool Duo Slab fixed to the non-fire side face with 100mm Stone Mineral Wool insulation between the LGS studs. 2 No. Double Sockets were also fitted on the Fire Side.	IS EN 1365-1:2012	90 mins from exposed side	1(a), 1(b), 1(c), 1(d), 2(a), 2(b), 3, 4(a) and 5
Internal Loadbearing Walls				
4	LGS C-Studs (90mmx47mmx1.2mm) with 1No. layer 12.5mm Type F plasterboard fixed to the fire side face and 1No. layer 12.5mm Type F plasterboard fixed to the non-fire side with 100mm stone mineral wool insulation between the LGS studs. 2 No. Double Sockets were also fitted on the Fire Side.	IS EN 1365-1: 2012	30 mins from inside	1(a), 1(b), 1(c), 1(d), 2(a), 2(b), 3, 4(a) and 5
5	LGS C-Studs (90mmx47mmx1.2mm) with 2No. layers 15mm Type F plasterboard fixed to the fire side face and 2 No. layer 15mm Type F plasterboard fixed to the non-fire side with 100mm stone mineral wool insulation between the LGS studs. 2 No. Double Sockets were also fitted on the Fire Side.	IS EN 1365-1:2012	60 mins from exposed side	1(a), 1(b), 1(c), 1(d), 2(a), 2(b), 3, 4(a) and 5
6	LGS C-Studs (90mmx47mmx1.2mm) with 3No. Layers of 12.5mm Type F Plasterboard fixed to the fire side face and 3No. Layers of 12.5mm Type F Plasterboard fixed to the non-fire side face with 100mm Stone Mineral Wool insulation between the LGS studs. 2 No. Double Sockets were also fitted on the Fire Side.	IS EN 1365-1:2012	90 mins from exposed side	1(a), 1(b), 1(c), 1(d), 2(a), 2(b), 3, 4(a) and 5
Separating Walls				
7	Twin Frame Wall 2 No. Layers of 15mm Type F plasterboard fixed to the fire side face of the LGS C-Studs (90mmx47mmx1.2mm) with 100mm stone mineral wool insulation between the LGS studs, 40mm cavity, LGS C-Studs (90mmx47mmx1.2mm) insulation between the LGS studs with 2 No. Layers of 15mm Type F plasterboard fixed to the fire side face of the LGS studs.	IS EN 1365-1:2012	60 mins from exposed side	1(a), 1(b), 1(c), 1(d), 2(a), 2(b), 3, 4(a) and 5
8	Twin Frame Wall 3 No. Layers of 12.5mm Type F plasterboard fixed to the fire side face of the LGS C-Studs (90mmx47mmx1.2mm) with 100mm stone mineral wool insulation between the LGS studs, 40mm cavity, LGS C-Studs (90mmx47mmx1.2mm) insulation between the LGS studs with 3 No. Layers of 12.5mm Type F plasterboard fixed to	IS EN 1365-1:2012	90 mins from either side	1(a), 1(b), 1(c), 1(d), 2(a), 2(b), 3, 4(a) and 5

	the fire side face of the LGS studs.			
Compartment Floors: Loaded Floors Joist or Truss				
9**	Floor supporting an Imposed Load of 1.5kN/m² 1No. layer of 12.5mm standard plasterboard, onto LGS Top Hat sections to form service cavity, onto 2no. layers of 12.5mm Type F plasterboard, onto 250mm LGS Floor Trusses at 400mm centres, with 150mm stone mineral wool between the trusses, with 18mm OSB3 floor deck screwed to the top of the floor trusses.	IS EN 1365-2:2014	60 mins from below ceiling level	1(a), 1(b), 1(c), 1(d), 2(b), 3, 4(a) and 5
Compartment Floors: Loaded Floors Composite Metal Deck				
10	Loaded Floor supporting Imposed Load of 2.0kN/m² 140mm normal weight concrete with 0.9mm Comflor 60 (CF60). Concrete reinforced with 12mm diameter bar in trough with nominal 30mm cover and A193 Mesh with a minimum 30mm cover to the top of the reinforcing mesh – 4500mm span propped at centre of span.	Eurocode Design	30 mins from below deck	1(a), 1(b), 1(c), 1(d), 2(a), 2(b), 3, 4(a) and 5
11	Loaded Floor supporting Imposed Load of 2.0kN/m² 160mm normal weight concrete with 1.2mm Comflor 60 (CF60). Concrete reinforced with 12mm diameter bar in trough with nominal 30mm cover and A252 Mesh with a minimum 30mm cover to the top of the reinforcing mesh 5250mm span propped at centre of span.	Eurocode Design	60 mins from below deck	1(a), 1(b), 1(c), 1(d), 2(a), 2(b), 3, 4(a) and 5
12	Loaded Floor supporting Imposed Load of 2.0kN/m² 160mm normal weight concrete with 1.2mm Comflor 60 (CF60). Concrete reinforced with 16mm diameter bar in trough with nominal 30mm cover and A252 Mesh with a minimum 30mm cover to the top of the reinforcing mesh 5250mm span propped at centre of span.	Eurocode Design	90 mins from below deck	1(a), 1(b), 1(c), 1(d), 2(a), 2(b), 3, 4(a) and 5
13	Loaded Floor supporting Imposed Load of 2.0kN/m² 160mm normal weight concrete with 1.2mm Comflor 60 (CF60). Concrete reinforced with 16mm diameter bar in trough with nominal 30mm cover and A252 Mesh with a minimum 30mm cover to the top of the reinforcing mesh 3650mm span propped at centre of span.	Eurocode Design	120 mins from below deck	1(a), 1(b), 1(c), 1(d), 2(a), 2(b), 3, 4(a) and 5
Notes:				
<ul style="list-style-type: none"> • Type F plasterboard refers to the particular type of plasterboard tested in the respective fire tests and the details are available directly from Metal Frame Construction. • Stone mineral wool refers to the particular type and density of stone mineral wool used in a particular fire test and the details are available directly from Metal Frame Construction. • All wall tests were completed without the joints being taped and jointed. • For alternative approaches to fire safety requirements, refer to 0.2 of TGD B (2020 reprint) to Part B of the Building Regulations 1997 to 2023. <p>* Non-loadbearing wall fire resistance data is provided from the Load Bearing Test Data and can be utilised under the Field of Direct application whereby the load can be decreased on the specimen.</p> <p>** Purpose Class 2(a) is removed from the construction in compliance with 3.2.5.1 of TGD B (2020 reprint) to Part B of the Building Regulations 1997 to 2023.</p>				

External walls U-value for variable PIR thickness

Wall build-up:

- Layer 7: Brick/masonry cladding
- Layer 6: 50mm low E cavity
- Layer 5: Variable PIR layer ⁽²⁾⁽³⁾ (see below)
- Layer 4: LGS/MW insulation ⁽¹⁾
- Layer 3: AVCL
- Layer 2: 12.5mm Plasterboard
- Layer 1: 12.5mm Plasterboard

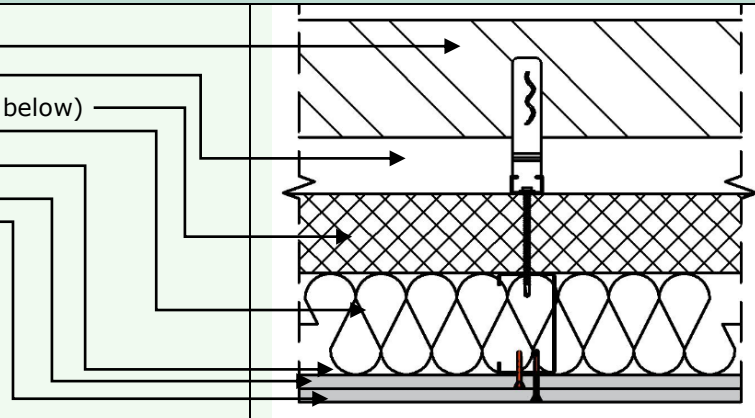

Wall thickness	PIR variable thickness:	Calculated U-value (W/m ² K)
320mm	60mm	0.21
330mm	70mm	0.2
340mm	80mm	0.18
350mm	90mm	0.17
360mm	100mm	0.16
370mm	110mm	0.15
380mm	120mm	0.14
390mm	130mm	0.14

Calculation comply with BRE Digest 465 *U-values for light steel-frame construction*

⁽¹⁾ Corrections have been made for 1.2mm LGS studs @ 407mm c/c bridging layer 4.

⁽²⁾ A level 1 correction for air voids has been applied to layer 5 (IS EN ISO 6946 Table D.1)

⁽³⁾ Correction for mechanical fasteners have been applied to layer 5 equating to 6 No. 5.5mm Ø

Stainless steel fixing to connect brick tie channel to LGS section.

Table 5: Typical External Wall U-Values

Sample U-value Calculation for 80mm PIR					
Layer	Description	% Bridged	Thickness [mm]	Thermal conductivity λ [W/m K]	Thermal resistance R [W/m ² K]
	R _{si}				0.13
1	Firecheck Plasterboard		12.5	0.25	0.05
2	Firecheck Plasterboard		12.5	0.25	0.05
3	AVCL				
4	Steel Stud	0.002	89	50	0.00178
	Mineral Wool	0.998	89	0.04	2.225
5	Variable PIR Insulation		80	0.022	3.636
6	Cavity Low-e (0.9, 0.2)		50	0.112	0.44
7	Brickwork Outer Leaf		102.5	0.77	0.133
	R _{se}				0.04
R _u Total =					6.695
R _L Total =					4.961
From BRE Digest 465 $P = 0.681, R_T = pR_{max} + (1 - p)R_{min} =$					<u>6.141854</u>
Correction term, $\Delta U =$					<u>0.017</u>
Corrected U-Value (2DP) =					0.18 W/m ² K
Correction as described in Table 5 apply					

Table 6: Sample U-value calculation for 80mm PIR

Effect on 0.18 W/m ² K (80mm PIR) U-value for variations in LGS thickness and centres						
Centres of studs	LGS Thickness (Gauge)					
	0.8m	1.0mm	1.2mm	1.5mm	2.0mm	2.5mm
300mm	0.189	0.191	0.193	0.194	0.196	0.197
400mm	0.182	0.184	0.1848	0.186	0.188	0.189
600mm	0.176	0.177	0.178	0.179	0.181	0.182

Table 7: Effect on U-value for variations in LGS thickness and centres

Ground Floor slab U-value for varying P/A ratio											
P/A Ratio	0.10	0.15	0.20	0.25	0.30	0.35	0.40	0.45	0.50	0.55	0.60
U-value	0.0865	0.097	0.105	0.11	0.114	0.116	0.119	0.12	0.122	0.123	0.124
Floor U-values based on 150mm RC Slab on 150mm PIR insulation ($\lambda=0.022$) on soil ($\lambda=2.0$). P/A Ratio = Exposed perimeter of the floor to total ground-floor area ratio.											

Table 8: Typical Ground Floor U-Values

Target linear thermal transmittance (ψ) for different types of junctions.					
ACD Ref:	Junction Description	Temperature Factor f_{Rsi} (Min = 0.75)	MFC Ψ -value (W/m.K)		TGD L Default Ψ -value
5.02	Ground Floor - Insulation below slab ⁽²⁾	0.77	0.195	>	0.106
N/A	Intermediate (Concrete) Floor	0.96	0.027		N/A
5.04	Separating Wall (plan) ⁽¹⁾⁽²⁾	0.9	0.04	<	0.057
5.05	Separating Wall top (section) ⁽¹⁾	0.845	0.128	>	0.095
5.07/5.08	Eaves ⁽²⁾	0.772	0.155	>	0.026
5.13	Gable ⁽²⁾	0.87	0.056	>	0.049
5.19	Ope - Lintel ⁽²⁾	0.89	0.042	>	0.016
5.20	Ope - Jambs ⁽²⁾	0.9	0.043	>	0.019
5.21	Ope - Sill ⁽²⁾	0.86	0.066	>	0.021
5.22.1	Steel Separating Wall through ground floor (base) ⁽¹⁾	N/A	0.0175	<	0.132
5.22.2	Steel Partition Wall through ground floor (base) ⁽¹⁾	N/A	0.047	<	0.074
5.23.1	Corner ⁽²⁾	0.84	0.057	>	0.029
⁽¹⁾ Value of ψ is applied to each dwelling. ⁽²⁾ Some ψ -values do not meet the default ψ -values, however all junctions pass f_{Rsi} assessments. ⁽³⁾ Flanking element U-values for walls, roof and floor thermal models above were based on, $U_W = 0.156$ W/m ² k, $U_F = 0.147$ W/m ² k, $U_R = 0.207$ W/m ² k Modelled junction ψ -values are based on typical Metal Frame Construction details above can be used in ψ -value calculations, if relevant detail is applicable.					

Table 9: Typical ψ -Value W/mK

Please note: All U-value calculations illustrated in the above Tables 5 to 8 should be taken as examples of performance that can be achieved. It is strongly recommended that U-value calculations are produced on a project specific basis by a competent person as U-value calculations may increase or decrease depending on a wide range of parameters such as number of fixings per square metre, size of fixing, emissivity of PIR surface facing into cavity etc, therefore U-values should be recalculated if the build-ups differ from those described in Tables 5 to 8.

4.5 SOUND

4.5.1 Party Wall

The acoustic performance of the party wall specified in Section 2.5.1 has been assessed by *SCI Publication P372 Acoustic Detailing for Steel Construction*^[46] and through adopting best practice at salient junctions to minimise the effects of airborne, impact and flanking sound. In respect of party walls (separating wall) an examination was also carried out of the key junctions in the external walls to ensure compliance with the requirements of Part E of the Building Regulations 1997 to 2023.

The specification for the separating wall achieves airborne sound insulation through the following:

- Structural isolation is achieved by leaving a minimum 40mm cavity between the two steel frames.
- Stone mineral wool of minimum 22kg/m³ density is placed between the studs in each frame. These wool batts are continuous from ground floor to the upper floor ceiling level and provide the required acoustic properties.
- Mass is achieved using dense wall linings. Each steel frame is boarded with the required number of layers of plasterboard required to provide the minimum total mass per unit area of 22kg/m² per face. All joints between the outer layer of plasterboard layer are staggered, taped and filled (where required for decoration) in accordance with manufacturers specifications.
- Prevention of flanking sound by sealing between the end of the separating wall frames and the outer masonry leaf.
- At the junction of the joist/truss compartment floor and the party wall, an additional 500mm section of stone mineral wool insulation is provided within the cavity between the two steel frames to minimise flanking and direct sound transmission.

The separating wall (party wall) in the Metal Frame Construction Steel Frame Building System has been assessed and when constructed in accordance with this Certificate can meet the requirements of TGD to Part E of the Building Regulations 1997 to 2023.

4.5.2 Compartment Floor Truss

The acoustic performance of the compartment floor specified in Section 2.5.3.1 has been assessed by comparison with Robust Standard Details for Separating Floor-Metal Joist E-FS-3 and *SCI Publication P372 Acoustic Detailing for Steel Construction*. Best practice has been adopted at salient junctions to minimise the effects of airborne, impact and flanking sound. In respect of compartment floor (separating floor) an examination was also carried out of the key junctions with the external walls to ensure

compliance with the requirements of Part E of the Building Regulations 1997 to 2023.

4.5.3 Compartment Floor Steel Concrete Composite Deck

The composite deck can meet the sound requirements for both floor types (FT) as described in section 4 of TGD to Part E of the Building Regulations 1997 to 2023. Floor **Type 1 (FT 1)** is a concrete base with a soft covering. A **Type 2 (FT 2)** is a concrete base with a floating floor.

In both floor types the resistance to airborne sound depends mainly on the mass of the concrete base, plasterboard ceilings and good flanking detailing. In Type 1 the soft covering reduces the impact sound at source. The mass per unit area of the floor, coverings and ceilings meet the specification for a Type 1 separating floor. The impact sound reduction is achieved with the use of a suitably approved 5mm layer of soft floor covering. This covering is not intended to be the final finished floor but is intended to act as resilient layer beneath different floor finishes such as vinyl, carpet, timber flooring, tiles etc.

In the Type 2 floor with a concrete base and a floating layer, the floating layer reduces the transmission of impact sound to the base and to the surrounding construction.

4.5.4 Lightweight Floating Floors on Compartment Floors

A lightweight floating floor consists of a floating layer and resilient layer. A floating floor uses a resilient layer to isolate the walking surface from the base and this isolation contributes to both airborne and impact sound insulation. The joist and steel concrete composite deck compartment floor systems have been assessed with both an approved batten system and an acoustic flooring grade stone mineral wool product.

4.6 ACCESS FOR PEOPLE WITH DISABILITIES

4.6.1 Access and Use

Building designs can accommodate minimum dimensions for doors/corridors/rooms and circulation spaces to provide access for people with disabilities as indicated in Diagrams 5 – 12 of TGD to Part M of the Building Regulations 1997 to 2023.

4.6.2 Sanitary Conveniences

Buildings can be designed to meet the installation requirements for all necessary and special sanitary conveniences for people with disabilities.

4.7 WEATHERTIGHTNESS AND DAMP PROOFING

Thresholds shall be detailed to allow level access (as required), while protecting the steel frame

from weather and ground moisture. Weep holes and cavity vents should be avoided in immediate threshold areas and should be placed on either side of the threshold.

4.7.1 Floor Damp Proofing

The system has adequate DPCs and DPMs to resist the passage of moisture from the ground.

4.7.2 Roof Cladding

Roof coverings will provide adequate weather resistance in all situations covered by Section 3 of this Certificate, when completed in accordance with this Certificate and the Manufacturer's instructions.

4.7.3 External Cladding

The external wall with masonry/brick outer leaf incorporates a 50mm, 75mm or 100mm clear cavity, when correctly constructed with well filled perpend and mortar-free cavity ties, will minimise the risk of water reaching the cavity face of the inner leaf. For other NSAI Agrément approved wall cladding systems in exposed areas, a water barrier is fixed behind the 25mm (clean) cavity between inner leaf and external cladding, and this minimises the risk of water reaching the inner leaf. Joints, in the insulating lining to the inner leaf, are weatherproofed and any penetrations are sealed. Wind-driven rain, which may cross the cavity under adverse conditions, will be effectively prevented from penetrating the inner leaf.

The construction of the external panels also keeps the galvanised steel frame members in a "warmframe" environment, which prolongs the life of the steel. Stepped DPC must be provided over window and door heads to deflect moisture that enter the cavity from entering the dwelling/building. Good building practice such as stepped DPC and weep-holes are essential to ensure that moisture within a cavity is deflected to the outside of the building.

4.7.4 Windows and Doors

This Certificate does not cover the installation or performance of windows and doors. However, the detailing at window and door openings has been assessed and is considered adequate to ensure that water penetration will not occur at these locations assuming conventional window frame profiles and sealing arrangements are used.

Window sills and external thresholds must either be impervious, run the full width of the cavity and be suitably jointed to a horizontal, continuous cavity tray or DPC which is preferably flexible, or a cavity tray must be provided under the opening provision. Good attention to detail must be given to ensuring that, when installing the horizontal cavity tray or DPC below an external window board, provision for any

condensation that may occur on the window is deflected into the cavity and away from the steelwork. The windows and doors are made to order by the window manufacturer using the dimensions provided by the Metal Frame Construction design office.

4.7.5 Rain Water Goods

Buildings constructed using the Metal Frame Construction Steel Frame Building System can readily accommodate adequate rainwater gutters and down pipes.

4.8 ELECTRICAL AND PLUMBING SERVICES

Electrical and plumbing services are outside the scope of this Certificate. However, in designing and installing these services it is essential that the following procedures are followed, and precautions are taken to minimise the risk of long-term damage to the steel frame or the services.

- At the design stage, it is useful if the positions and sizes of services can be established in advance, as special holes may be cut in the factory to help with the rapid and economic installation of services. A considerable amount of services is generally required in bathroom, hot press and utility areas.
- In general, the steel frame at each floor level must be connected directly onto the main earthing terminal in the main fuse box and all earth connections in the circuit wired back to this point. This measure is necessary to control the flow of electric current to earth without the risk of corrosion of critical structural components. However, the earthing system must be installed in accordance with I.S. 10101^[40], the National Rules for Electrical Installations.
- All unswaged service holes in the steel frame members must be fitted with rubber or plastic grommets to avoid damage to services. To ease the installation of services, particularly electrical cables, these purpose-made rubber or polyethylene grommets form the inner face of the openings. The service holes may alternatively be formed by swaging which is fully rounded to offer a non-sharpened surface to the services. Where plastic coated electrical wiring is in contact with insulation, then the cables must be enclosed in a suitable conduit, e.g. PVC, in accordance with I.S. 10101, the National Rules for Electrical Installations.
- Under no circumstances should electrical cables be placed within compartment floors, walls and/or separating walls. Walls must be battened out to provide a false service zone in which to distribute electrical services on these fire rated build-ups.
- The enclosure of cold-water pipe work within the external wall should be avoided as condensation on the pipe work could lead to

wetting of the steel frame with a consequent risk of corrosion. If enclosure is unavoidable, the cold-water pipework must be insulated with tubular plastic insulation, which must be accurately cut at junctions and at changes of direction and held firmly in place with adhesive tape. Where hot water pipework is enclosed in the inner leaf of the wall, contact between copper pipes and the galvanised frame must be avoided using rubber or plastic grommets.

- Additional slots, notches or holes should not be cut through any steel member without the approval of the Chartered Structural Engineer responsible for the overall design of the structure.

4.9 DURABILITY

The steel frame structure and wall cladding has been assessed as capable of achieving a minimum design life of 60 years. The steel structure is constructed from steel members having a minimum 275g/m² Zinc galvanised coating which will provide adequate protection to the steel members. In addition to this, the steel is kept in a "warmframe" environment, which should prolong the life of the steel. The DPC and the galvanising will provide adequate protection to ensure that the bottom channel has a life equal to that of the other frame members.

The insulations are durable materials and will remain effective as an insulant for the life of the building. The roof, internal wall and ceiling linings and the outer leaf of the external wall are all constructed from durable materials.

Buildings constructed using the Metal Frame Construction Steel Frame Building System will, when constructed in accordance with Metal Frame Construction Erection Manual and the requirements of this Certificate along with all relevant codes of practice will have a minimum design life of at least 60 years in accordance with BS 7543:2015.

4.10 MAINTENANCE

Maintenance will be required at a level comparable with that for buildings of traditional construction. The elimination of wet trades in the construction of the inner leaf of external walls reduces drying time and can reduce the incidence of superficial cracking early in the life of the building.

As the plasterboard is screwed into the steel structure, there is no nail popping in plasterwork, which results in less maintenance of plasterwork, than that of a traditionally constructed building.

Repainting should be carried out in accordance with the relevant recommendations of BS 6150^[39]. Timber boarding, fascia's, soffits etc.

where used, should be treated with an appropriate paint system or translucent stain and should be maintained by periodic re-coating using a paint or stain suitable for external applications, applied in accordance with the manufacturer's instructions.

The joints in windows and doors may require resealing at approximately 10-year intervals.

4.11 TESTS AND ASSESSMENTS WERE CARRIED OUT TO DETERMINE THE FOLLOWING

The following is a summary of the tests and assessments which have been carried out on the Metal Frame Construction Steel Frame Building System:

- Structural strength and stability (racking resistance, load bearing capacity).
- Behaviour in relation to fire.
- Acoustic performance, resistance to airborne and impact sound transmission.
- Thermal insulation performance.
- Corrosion of fasteners in normal conditions with a view to a minimum 60-year design life.
- Compatibility with other materials.
- Risk of condensation both surface and interstitial.
- Pre-completion airtightness testing.
- 3D thermal modelling of junction details in accordance with BRE IPI/06.

4.11.1 Other Investigations

Existing data was examined to assess:

- Adequacy of weather tightness of building constructed using the system.
- Durability of the system.
- Requirements for maintenance.

4.11.2 Production Audits

Production audits were carried out at the Metal Frame Construction factory to examine the process of structural design, steel frame fabrication, assembly and to assess the adequacy of the methods adopted for quality control.

4.11.3 Site Erection Visits

Buildings under construction were visited to assess the practicability of construction (erection) and the adequacy of Metal Frame Construction site supervision arrangements.

5.1 National Standards Authority of Ireland ("NSAI") following consultation with NSAI Agrément has assessed the performance and method of installation of the product/process and the quality of the materials used in its manufacture and certifies the product/process to be fit for the use for which it is certified provided that it is manufactured, installed, used and maintained in accordance with the descriptions and specifications set out in this Certificate and in accordance with the manufacturer's instructions and usual trade practice. This Certificate shall remain valid for five years from date of latest revision so long as:

- (a) the specification of the product is unchanged.
- (b) the Building Regulations 1997 to 2023 and any other regulation or standard applicable to the product/process, its use or installation remains unchanged.
- (c) the product continues to be assessed for the quality of its manufacture and marking by NSAI.
- (d) no new information becomes available which in the opinion of the NSAI, would preclude the granting of the Certificate.
- (e) the product or process continues to be manufactured, installed, used and maintained in accordance with the description, specifications and safety recommendations set out in this certificate.
- (f) the registration and/or surveillance fees due to IAB are paid.

5.2 The NSAI Agrément mark and certification number may only be used on or in relation to product/processes in respect of which a valid Certificate exists. If the Certificate becomes invalid the Certificate holder must not use the NSAI Agrément mark and certification number and must remove them from the products already marked.

5.3 In granting Certification, the NSAI makes no representation as to;

- (a) the absence or presence of patent rights subsisting in the product/process; or
- (b) the legal right of the Certificate holder to market, install or maintain the product/process; or
- (c) whether individual products have been manufactured or installed by the Certificate holder in accordance with the descriptions and specifications set out in this Certificate.

5.4 This Certificate does not comprise installation instructions and does not replace the manufacturer's directions or any professional or trade advice relating to use and installation which may be appropriate.

5.5 Any recommendations contained in this Certificate relating to the safe use of the certified product/process are preconditions to the validity of the Certificate. However, the NSAI does not certify that the manufacture or installation of the certified product or process in accordance with the descriptions and specifications set out in this Certificate will satisfy the requirements of the Safety, Health and Welfare at Work Act 2005, or of any other current or future common law duty of care owed by the manufacturer or by the Certificate holder.

5.6 The NSAI is not responsible to any person or body for loss or damage including personal injury arising as a direct or indirect result of the use of this product or process.

5.7 Where reference is made in this Certificate to any Act of the Oireachtas, Regulation made thereunder, Statutory Instrument, Code of Practice, National Standards, manufacturer's instructions, or similar publication, it shall be construed as reference to such publication in the form in which it is in force at the date of this Certification.

NSAI Agrément

This Certificate No. **19/0412** is accordingly granted by the NSAI to **Metal Frame Construction** on behalf of NSAI Agrément.

Date of Issue: 31st July 2019

Signed



Kevin D. Mullaney
Director of Certification, NSAI

Readers may check that the status of this Certificate has not changed by contacting NSAI Agrément , NSAI, 1 Swift Square, Northwood, Santry, Dublin 9, Ireland. Telephone: (01) 807 3800. Fax: (01) 807 3842. www.nsai.ie

Revisions

- **14th October 2024:** 5 Year reassessment

Bibliography

- [1] BS 5250:2021 Management of moisture in buildings. *Code of practice for the control of condensation in buildings.*
- [2] IP 1/06:2006 *Assessing the effects of thermal bridging at junctions and around openings.*
- [3] BRE report BR 479:2016 *Conventions for calculating linear thermal transmittance and temperature factors.*
- [4] I.S. EN ISO 10211:2007 *Thermal Bridges in Building Construction - Heat Flows and Surface Temperatures - Detailed Calculations.*
- [5] S.R. 325:2013+A2:2018/AC:2019 *Recommendations for the design of masonry structures in Ireland to Eurocode 6.*
- [6] I.S. EN 845-1:2013+A1:2016 *Specification for ancillary components for masonry Part 1: Wall Ties, Tension Straps, Hangers and Brackets.*
- [7] I.S. EN 206:2013+A2:2021 *Concrete – Specification, Performance, Production and Conformity including National Annex;2015+AC2;2017*
- [8] BS 8102:2022 *Code of practice for protection of below ground structures against water from the ground.*
- [9] I.S. EN 10346:2015, *Continuously Hot-dip Coated Steel Flat Products for Cold Forming - Technical Delivery Conditions.*
- [10] I.S. EN 1090-1:2009+A1:2011 *Execution of Steel Structures and Aluminium Structures Part 1: Requirements for Conformity Assessment of Structural Components.*
- [11] I.S.EN 520:2004+A1:2009 *Gypsum plasterboards - Definitions, requirements and test methods.*
- [12] BS 8417:2024 *Preservation of wood - Code of practice*
- [13] BS 9991:2015 *Fire Safety in The Design, Management and Use of Residential Buildings -" Code of Practice.*
- [14] BS 9999:2017 *Fire Safety in the Design, Management and Use of Buildings - Code of practice.*
- [15] I.S. EN 1990:2002+NA:2010 *Eurocode – Basis of Structural Design.*
- [16] I.S. EN 1991-1-1:2002+NA:2013 *Eurocode 1: Actions on Structures Part 1-1: General actions - Densities, self-weight, imposed loads for buildings (including National Annex 2013).*
- [17] I.S. EN 1991-1-4:2005 *Eurocode 1: Actions on Structures Part 1-4: General Actions - Wind actions.*
- [18] I.S. EN 1991-1-3:2003/A1:2015+NA/A2:2020 *Eurocode 1 - Actions on Structures Part 1-3: General Actions. Snow Loads.*
- [19] I.S. EN 1992-1-2:2004 &AC:2008&A1:2019 *Eurocode 2: Design of Concrete Structures Part 1-1: General Rules and Rules for Buildings.*
- [20] I.S. EN 1992-1-1 NATIONAL ANNEX:2004/NA:2010/AC2:2020 *Eurocode 2: Design of Concrete Structures Part 1-1: General Rules and Rules for Buildings.*
- [21] I.S. EN 1992-4:2018 *Eurocode 2 -" Design of concrete structures -" Part 4: Design of fastenings for use in concrete.*
- [22] I.S. EN 1993-1-1:2005 *Eurocode 3 -" Design of steel structures -" Part 1-1: General rules and rules for buildings (including 2005 Irish National Annex).*
- [23] I.S. EN 1993-1-3:2006 *Eurocode 3 - Design of Steel Structures - Part 1-3: General Rules – Supplementary Rules for Cold-Formed Members and Sheeting (Including Irish National Annex).*

- [24] I.S. EN 1993-1-4:2006/A2:2020 *Eurocode 3 - Design of steel structures - Part 1-4: General rules - Supplementary rules for stainless steels*
- [25] I.S. EN 1993-1-5:2006:2006&AC:2009&A1:2017&A2:2019 and I.S. EN 1993-1-5 NATIONAL ANNEX:2010 to *Eurocode 3 - Design of Steel Structures - Part 1-5: Plated Structural Elements*.
- [26] I.S. EN 1995-1-1:2004 *Eurocode 5: Design of Timber Structures Part 1-1. General - Common rules and rules for Buildings*.
- [27] I.S. EN 1996-1-1:2005+A1:2012/NA:2010+A1:2014 *Eurocode 6 Design of Masonry Structures - Part 1-1: General Rules for Reinforced and Unreinforced Masonry Structures (including Irish National Annex)*.
- [28] I.S. EN 1997-1:2004+A1:2013 *Eurocode 7 Geotechnical Design – Part 1: General Rules*.
- [29] I.S. EN 1859:2009 *Chimneys – Metal chimneys – Test methods*.
- [30] BS 5234-1:1992 *Partitions (including matching linings). Code of practice for design and installation*.
- [31] I.S. EN 10143:2006 *Continuously Hot-dip Coated Steel Sheet and Strip - Tolerances on Dimensions and Shape*.
- [32] I.S. EN 10162:2003 *Cold Rolled Steel Sections - Technical Delivery Conditions - Dimensional and Cross-sectional Tolerances*.
- [33] I.S. EN 1364-1:2015 *Fire resistance tests for non-loadbearing elements, Part 1 -" Wall*.
- [34] I.S. EN 1365-1:2012 *Fire resistance tests for loadbearing elements, Part 1 -" Walls*.
- [35] I.S. EN 1365-2:2014 *Fire resistance tests for loadbearing elements, Part 2 -" Floors and roofs*.
- [36] I.S. EN ISO 9972:2015 *Thermal Performance of Buildings -" Determination of Air Permeability of Buildings -" Fan Pressurization Method*.
- [37] I.S. EN ISO 13788:2012 *Hygrothermal performance of building components and building elements and building elements -" Internal surface temperature to avoid critical surface humidity and interstitial condensation -" Calculation Methods*.
- [38] BS 7543:2015 *Guide to durability of buildings and building elements, products and components*.
- [39] BS 6150:2006+A1:2014 *Painting of buildings - Code of Practice*.
- [40] I.S. 10101: 2020 + AC1:2020 *National Rules for Electrical Installations*
- [41] BS 8210:2020: *Facilities maintenance management , Code of practice*.
- [42] I.S. EN ISO 16283-1:2014/A1:2017 *Acoustics - Field Measurement of Sound Insulation in Buildings and of Building Elements Part 1: Airborne Sound Insulation*.
- [43] I.S. EN ISO 16283-2: 2020: *Acoustics - Field measurement of sound insulation in buildings and of building elements - Part 2: Impact sound insulation*.
- [44] I.S. EN 13501-1:2018 *Fire Classification of Construction Products and Building Elements Part 1: Classification Using Data from Reaction to Fire Tests*.
- [45] I.S. EN ISO 6946:2017 *Building components and building elements - Thermal resistance and thermal transmittance - calculation method*.
- [46] SCI Publication P372:2008 *Acoustic Detailing for Steel Construction*.
- [47] HSA:2017 *Code of Practice for the Design and Installation of Anchors*.