

Kilsaran External Wall Insulation System for Infill & Loadbearing LGS Structures

NSAI Agrément (Irish Agrément Board) is designated by Government to issue European Technical Approvals.

NSAI Agrément Certificates establish proof that the certified products are '**proper materials**' suitable for their intended use under Irish site conditions, and in accordance with the **Building Regulations 1997 to 2021**.



SCOPE

This Certificate relates to the Kilsaran External Wall Insulation (KEWI) System for use with infill and load bearing LGS structures. The system is a mechanically fixed external insulated render system with a non-ventilated drained cavity designed for use with NSAI certified LGS systems with studs at max 600mm centres that reference this certificate and are certified for infill and structural LGS up to 30m in height.

The Ceresit Ceretherm mineral wool external insulation system used in the KEWI system is supplied by Henkel Polska.

The KEWI System is certified for use in buildings up to 30m in height to the top floor in purpose groups 1(a), 1(b), 1(c), 1(d), 2(a), 2(b), 3, 4(a), 4(b) and

5 as defined in Technical Guidance Document B of the Building Regulations 1997 to 2021.

In the opinion of NSAI, the KEWI System, as described in this Certificate, complies with the requirements of the Building Regulations 1997 to 2021.

Kilsaran are responsible for the design and supply of the KEWI system. The system is designed by Kilsaran approved engineers on a project specific basis and in accordance with an approved design process.

The installation of the system is carried out by installers who have been trained by Kilsaran or a Kilsaran representative, approved by both Kilsaran and NSAI Agrément to install the system.

Applicators must adhere to strict installation guidelines as specified by Kilsaran.

MANUFACTURE, DESIGN AND MARKETING:

The Kilsaran External Wall Insulation (KEWI) System for infill and load bearing LGS structures is designed and supplied by:

Kilsaran,
Piercetown, Dunboyne,
Co. Meath,
Ireland.
T: 01 802 6300
E: info@kilsaran.ie
W: www.kilsaran.ie

Part D – Materials and Workmanship

D1 – Materials & Workmanship

D3 – Proper Materials

The KEWI system is comprised of ‘proper materials’ i.e. materials which are fit for their intended use and for the conditions in which they are to be used.

Buildings incorporating the KEWI System can be designed to meet the requirements of the following clauses of the Building Regulations 1997 to 2021:

Part A - Structure

A1 – Loading

Part B – Fire Safety

For purpose group 1(a), 1(b) and 1(d) the fire safety requirements are outlined in TGD B Fire Safety Volume 2, Dwelling Houses of the Building Regulations 1997 to 2021. For purpose groups 1(c), 2(a), 2(b), 3, 4(a), 4(b) and 5 the fire safety

requirements are laid out in TGD B 2006 of the Building Regulations 1997 to 2021.

B4 & B9 – External Fire Spread

Note: In a building more than 18m high, all external wall cladding, including insulation material used in drained and/or ventilated cavities in the external wall construction should be of limited combustibility A2-s1, d0 rating to IS EN 13501-1^[3].

Part C – Site Preparation and Resistance to Ground Moisture

C4 – Resistance to Weather and Ground

Part E – Sound

E1 – Sound

Part L – Conservation of Fuel and Energy

L1 – Conservation of Fuel and Energy

2.1 PRODUCT DESCRIPTION

The KEWI system for infill and load bearing LGS structures is comprised of:

- NSAI certified LGS steel frame (with mineral wool insulation between the studs), supplied by steel frame supplier – full internal build-up of the LGS structure is per the NSAI Agrément certificate for that system.
- Kilsaran approved A2 Versapanel carrier board with a minimum A2-s1, d0 fire classification and CE marked where the intended use is for structural purpose.
- CE marked breather membrane & AVCL with a minimum B-s1, d0 fire classification.
- Kilsaran 20mm mechanically fixed Cavity Rail System.
- Mineral wool Ceresit Ceretherm external insulation system per ETA 09/0037 and 14/0127 – the render system used must have a minimum fire classification of A2-s1 d0 in accordance with I.S. EN 13501-1^[3].

This Certificate contains illustrations to explain the various elements of the KEWI System – these illustrations are not intended to be used as construction drawings. Kilsaran, in conjunction with the design team on a project, will produce a set of project specific details on a project by project basis. All drawings shall be compliant with the relevant codes of practice and relevant standards, along with current Building Regulations.

2.2 DESIGN, SUPPLY AND INSTALLATION

Kilsaran are responsible for the:

- Project specific design of the KEWI system for infill and load bearing LGS structures, in accordance with approved design process;
- Confirmation that the Kilsaran approved carrier board has been used and installed correctly prior to the installation of the drained cavity system, which is under Kilsaran supervision;
- Training, monitoring and review of licensed applicators in accordance with approved training and assessment procedures;
- Product supply of the external insulation system;
- Technical support and installation supervision, including installation of fire barriers.

The installation of the KEWI System is carried out by Kilsaran trained and approved installers in accordance with Kilsaran project specific specifications and method statements. Installers must also be approved and registered by NSAI Agrément under the NSAI Agrément External

Thermal Insulating Composite Systems (ETICS) Approval Scheme.

2.2.1 Quality Control

The Certificate holder operates a quality management system and a quality plan is in place for system design and installation.

2.3 DELIVERY, STORAGE AND MARKING

Kilsaran are responsible for the supply and design of the cavity rail system and the supply of all the components associated with the external insulation system. The external insulation is delivered to site in packs. Each pack is marked with the manufacturer's details, product identification marks and batch numbers. Each container for other components, e.g. renders, adhesives etc, bears the manufacturer's and the product's identification and batch number.

Insulation should be stored on a firm, clean, dry and level base, which is off the ground. The insulation should be protected from prolonged exposure to sunlight by storing opened packs under cover in dry conditions or by re-covering with opaque polythene sheeting. Mineral fibre board must be protected from moisture prior to and during installation. It may be necessary to remove and replace any unsuitable/wet material. Care should be taken when handling the insulation boards to avoid damage and contact with solvents or bitumen products.

Mortar, primers, renders, paints, texture synthetic finish coatings and sealants should be stored in accordance with the manufacturer's instructions, in dry conditions, at the required storage temperatures. They should be used within the stated pot or shelf life.

2.4 INSTALLATION

2.4.1 Approved Installers

Installation is carried out by Kilsaran trained applicators who are registered with NSAI Agrément as ETICS installers of the Ceresit system.

2.4.2 General

Kilsaran prepare a site package for each project. This pack would typically include wind load calculations, a fixing specification summary sheet, elemental wall U-value calculation, and a set of project specific building details.

Kilsaran provide the relevant loading to the LGS system supplier.

Deviations from specification must be approved by a Kilsaran technical representative. Kilsaran will provide ongoing checks on the installation in accordance with the project specific design.

Mineral wool must be protected from moisture prior to and during installation. It may be necessary to remove and replace any unsuitable/wet material.

2.4.3 Site Survey and Preliminary Work

A comprehensive pre-installation site survey of the property shall be carried out by Kilsaran.

2.4.4 Site Installation

- Upon completion of the NSAI certified LGS stud frame, a Kilsaran approved carrier board, with a minimum A2-s1, d0 fire rating, is mechanically fixed to LGS stud panel with Kilsaran approved fixings.
- Where the carrier board is installed by others, it must be inspected by Kilsaran prior to the installation of the membrane and cavity rails.
- Where the carrier board is installed by the Kilsaran approved installer, it must be installed as per the installation manual.
- A breather membrane, with a minimum B-s1, d0 fire classification, is fixed over the carrier board by the Kilsaran approved installer in accordance with the installation manual.
- Kilsaran's Cavity Rail System, consisting of base drip, corner, deflection and spacer rails is fixed to the carrier board, creating a minimum 20mm drainage cavity.
- Spacer rails positioning should be set out prior to work commencing. Rails are spaced in accordance with structural design requirements.
- Water deflection rails are fixed with stainless steel approved screws at 300mm c/c, at a slope across opens. A bead of Kilsaran approved mastic is used to seal the top of the rail.
- The base rail contains perforations to allow for any drainage of water that enters the system. Insect mesh is placed along the drainage holes of the base profile.
- Checks must be made to ensure the cavity rail system is fixed securely and correctly to the carrier board prior to further construction of the system.
- External mineral wool insulation as specified in Table 1, thickness dependent on project specific U values calculations, is fitted on top of the base rail and mechanically fixed to the rail system.
- Kilsaran approved fixings as specified in Table 1 and washers should be installed in accordance with structural design requirements, which is normally 6 per insulation board (1.2m x 0.6m) plus 1 fire fixing per m², unless otherwise specified. Protective caps should be put in after the anchor is secured.
- Insulation boards should be cut exactly to fit, to avoid gaps. To avoid thermal bridging, ensure a tight adhesive free joint connection between adjacent insulation boards. An intumescent filler approved by the Certificate holder may be used for filling gaps up to 5mm.
- At façade openings, e.g. windows and doors, insulation boards must be continued around the corner. Insulation boards overlap at these locations and can be cut to size to facilitate this. Any projecting mineral wool boards should be levelled out with local trimming.
- Checks must be made to ensure the insulation boards are fixed correctly through the cavity rail, prior to further construction of the system.
- The insulated wall is ready for the application of the Ceresit Ceretherm render system by Kilsaran approved and NSAI registered installer.
- Purpose-made powder coated aluminium window sills are part of the window package and are installed by the window installer – these sills are outside the scope of this Certificate. The external insulation is installed up to the bottom of the sill where a Kilsaran approved EPDM sealant and mastic sealant are used to ensure no water can get to the insulation under the sill.
- Cavity fire barriers and TENMAT FF102/50 intumescent fire stops are installed in accordance with the Certificate holder's instructions. See Section 3.3 for further information
- Movement joints shall be provided in accordance with the project specific site package.
- At all locations where there is a risk of rendered insulation exposure, e.g. window reveals, eaves or stepped gables, the system must be protected, e.g. by an adequate overhang or by purpose-made sub-sills, seals or flashings.
- Building corners, door and window heads and jambs are formed using stainless steel angle beads bonded to the insulation in accordance with the Certificate holder's instructions.

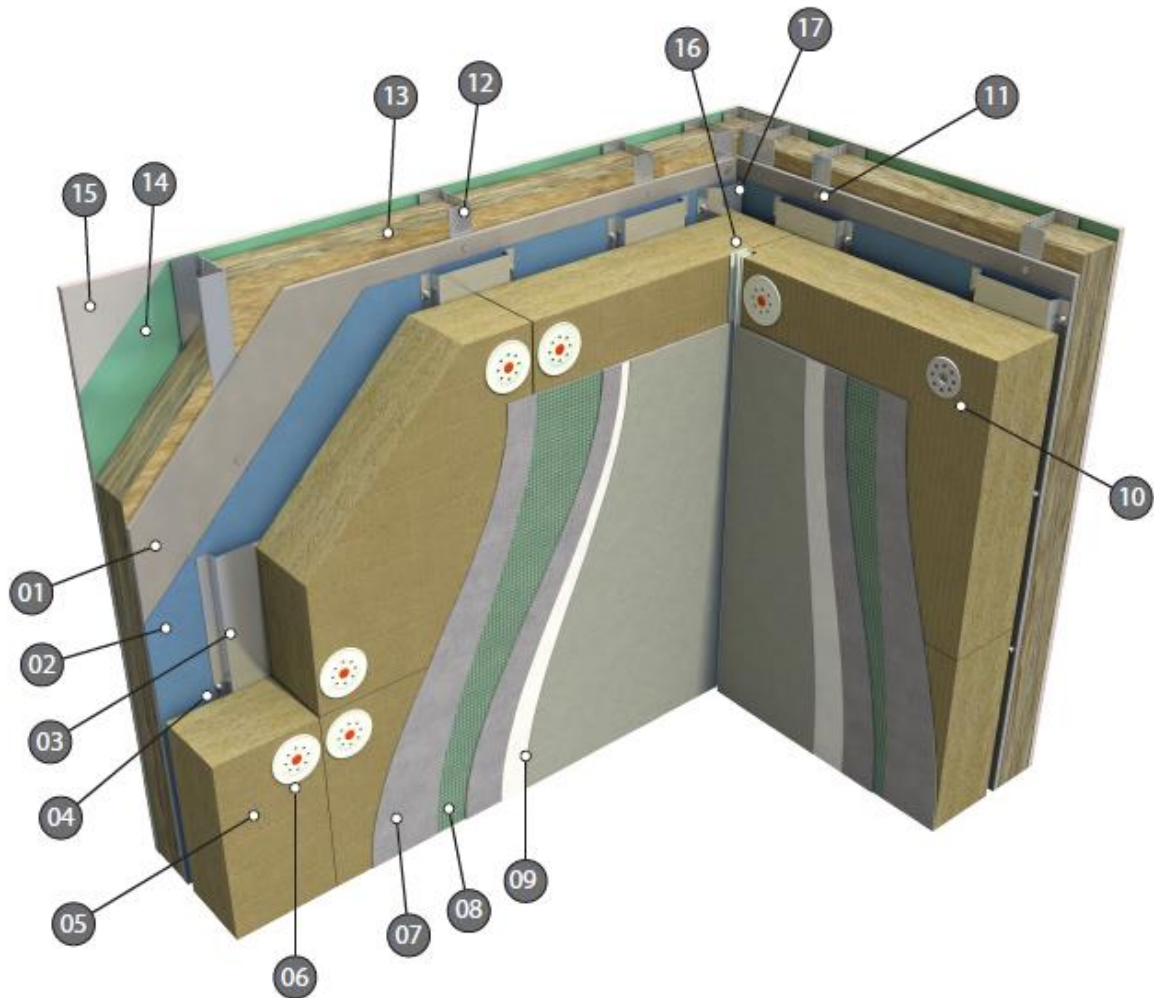

1. Sheathing Board^a
 2. Breather Membrane^a
 3. Spacer Rail
 4. Rail Profile Fixing
 5. Mineral Wool Insulation^b
 6. Kilsaran Fixing^b with 90mm Washer Head
 7. Ceresit Reinforcing Coat^b
 8. Two layers of Ceresit Reinforcing Mesh^b
 9. Ceresit Primer & Render^b
 10. Kilsaran Stainless Steel Fire Fixing^c & Washer Fixed Through the Mesh 1 per m²
 11. Kilsaran Sheathing Board SS Screw^c
 12. LGS Manufacturer Approved LGS System
 13. LGS Manufacturer Approved Insulation
 14. LGS Manufacturer Approved AVCL
 15. LGS Manufacturer Approved Boarding
 16. Kilsaran Movement Bead (as required)
 17. Frame Rail
- ^{a.} Per specification in Section 2.1
^{b.} Per specification in Table 1
^{c.d.} Per specification in Table 3b

Figure 1: Internal Corner Detail

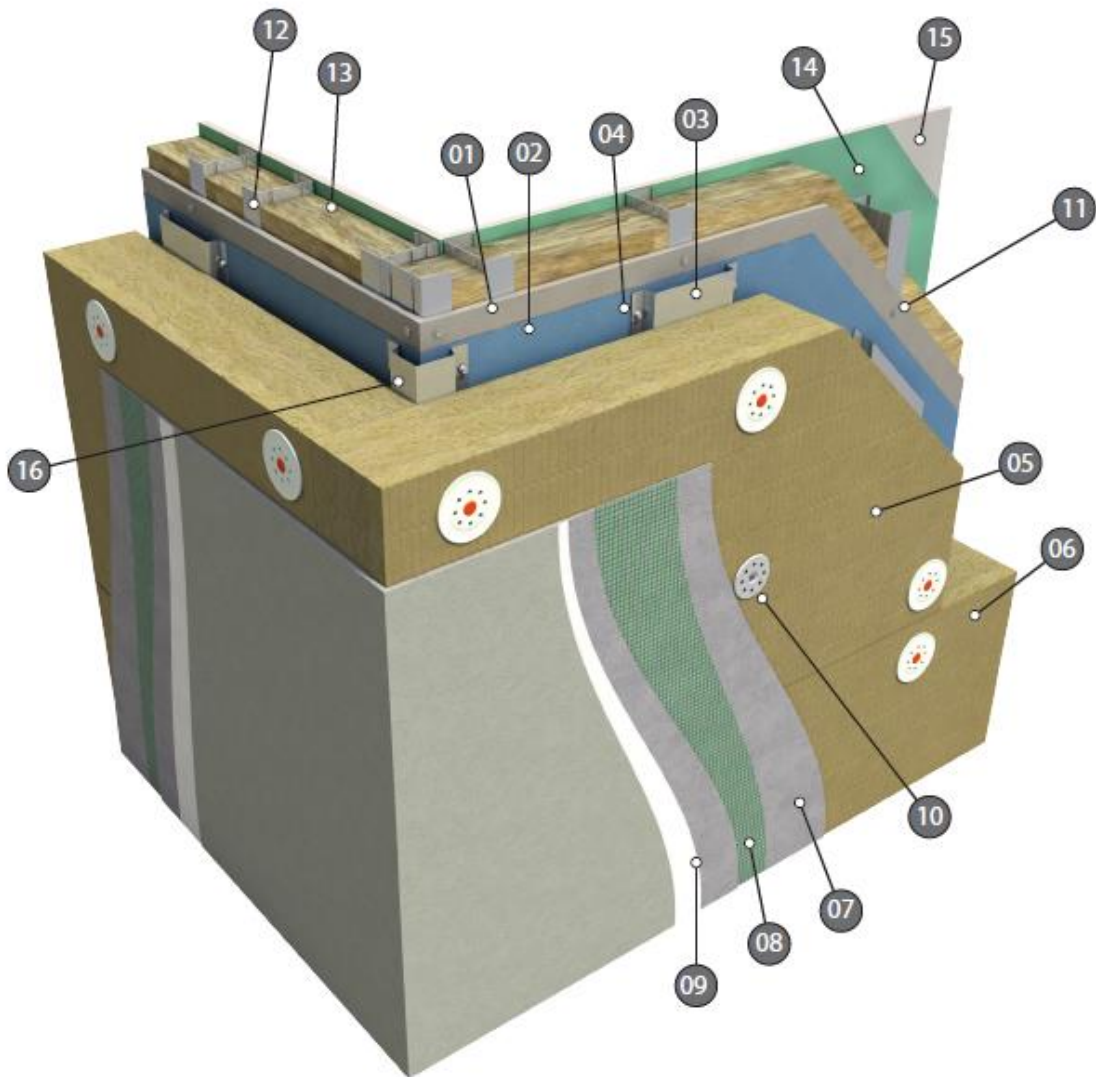

1. Sheathing Board^a
 2. Breather Membrane^a
 3. Spacer Rail
 4. Rail Profile Fixing^c
 5. Mineral Wool Insulation^b
 6. Kilsaran Fixing^b with 90mm Washer Head
 7. Ceresit Reinforcing Coat^b
 8. Two layers of Ceresit Reinforcing Mesh^b
 9. Ceresit Primer & Render^b
 10. Kilsaran Stainless Steel Fire Fixing^c & Washer Fixed Through the Mesh 1 per m²
 11. Kilsaran Sheathing Board SS Screw^c
 12. LGS Manufacturer Approved LGS System
 13. LGS Manufacturer Approved Insulation
 14. LGS Manufacturer Approved AVCL
 15. LGS Manufacturer Approved Boarding
 16. Corner Spacer Rail
- ^{a.} Per specification in Section 2.1
^{b.} Per specification in Table 1
^{c.} Per specification in Table 3b

Figure 2: External Corner Detail

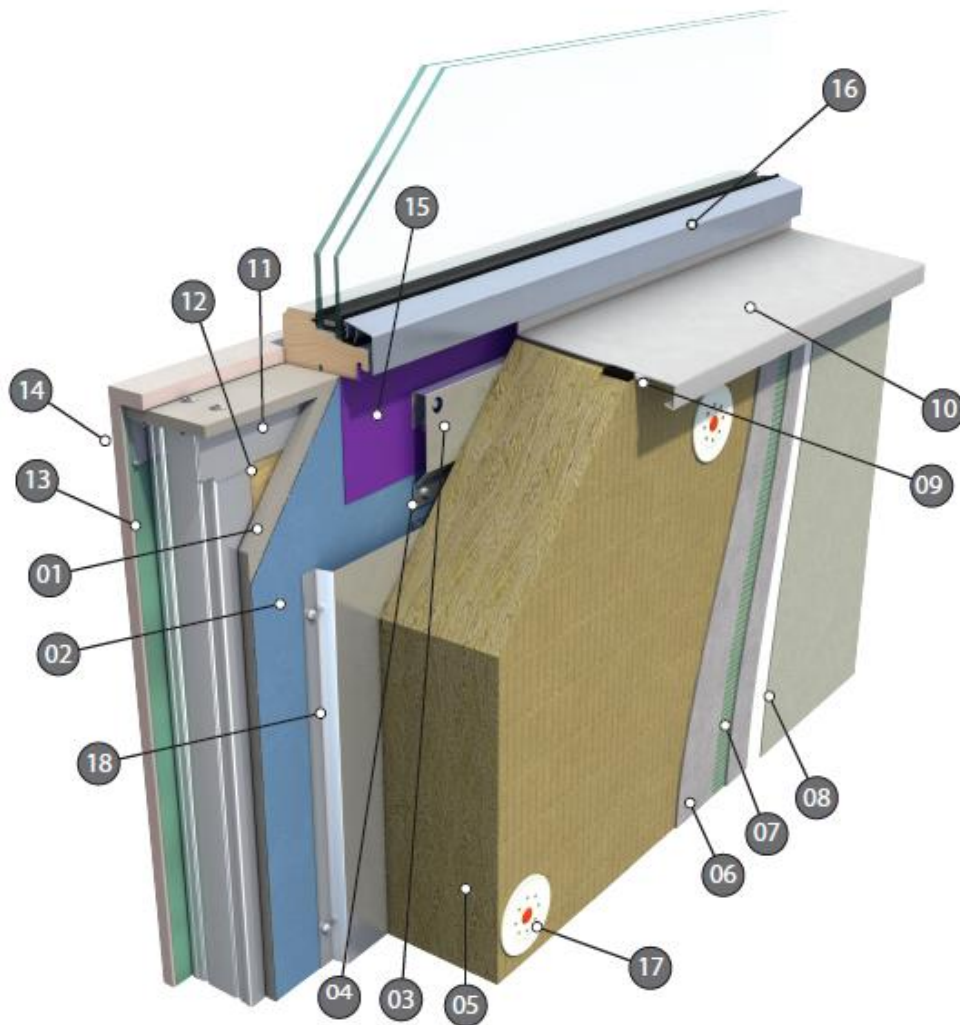

1. Sheathing Board^a
 2. Breather Membrane^a
 3. Spacer Rail
 4. Rail Profile Fixing^c
 5. Mineral Wool Insulation^b
 6. Ceresit Reinforcing Coat^b
 7. Two layers of Ceresit Reinforcing Mesh^b
 8. Ceresit Primer & Render^a
 9. Kilsaran Sealant
 10. Pressed Metal Window Sill (supplied as part of the Window System) with EPDM and mastic sealant underneath at interface with the insulation board
 11. LGS Manufacturer Approved LGS System
 12. LGS Manufacturer Approved Insulation
 13. LGS Manufacturer Approved AVCL
 14. LGS Manufacturer Approved Boarding
 15. Kilsaran EPDM Membrane Bonded and Sealed to Approved Sheathing Board
 16. Window Frame
 17. Kilsaran Fixing^c with 90mm PVC Washer Head
 18. Spacer Rail
- ^{a.} Per specification in Section 2.1
^{b.} Per specification in Table 1
^{c.} Per specification in Table 3b

Figure 3: Window Sill Detail

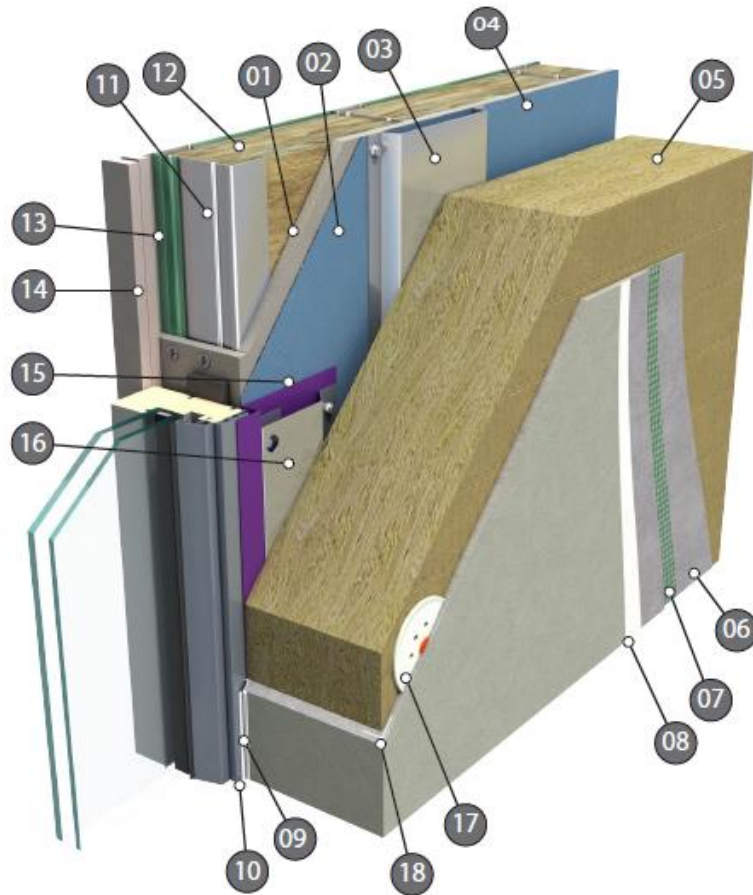

1. Sheathing Board^a
 2. Breather Membrane^a
 3. Spacer Rail
 4. Rail Profile Fixing^c
 5. Mineral Wool Insulation^b
 6. Ceresit Reinforcing Coat^b
 7. Two layers of Ceresit Reinforcing Mesh^b
 8. Ceresit Primer & Render^b
 9. Kilsaran Sealant at Junction of Reveal Board to Window Frame and Reveal Board to Window Sill
 10. Kilsaran Render Reveal Bead at Junction of Reveal Board to Window Frame and Reveal Board to Window Sill
 11. LGS Manufacturer Approved LGS System
 12. LGS Manufacturer Approved Insulation
 13. LGS Manufacturer Approved AVCL
 14. LGS Manufacturer Approved Boarding
 15. Kilsaran EPDM Membrane Bonded and Sealed to Approved Sheathing Board
 16. Frame Rail
 17. Kilsaran Fixing^c with 90mm PVC Washer Head
 18. Kilsaran Corner Bead
- ^{a.} Per specification in Section 2.1
^{b.} Per specification in Table 1
^{c.} Per specification in Table 3b

Figure 4: Window Reveal Detail

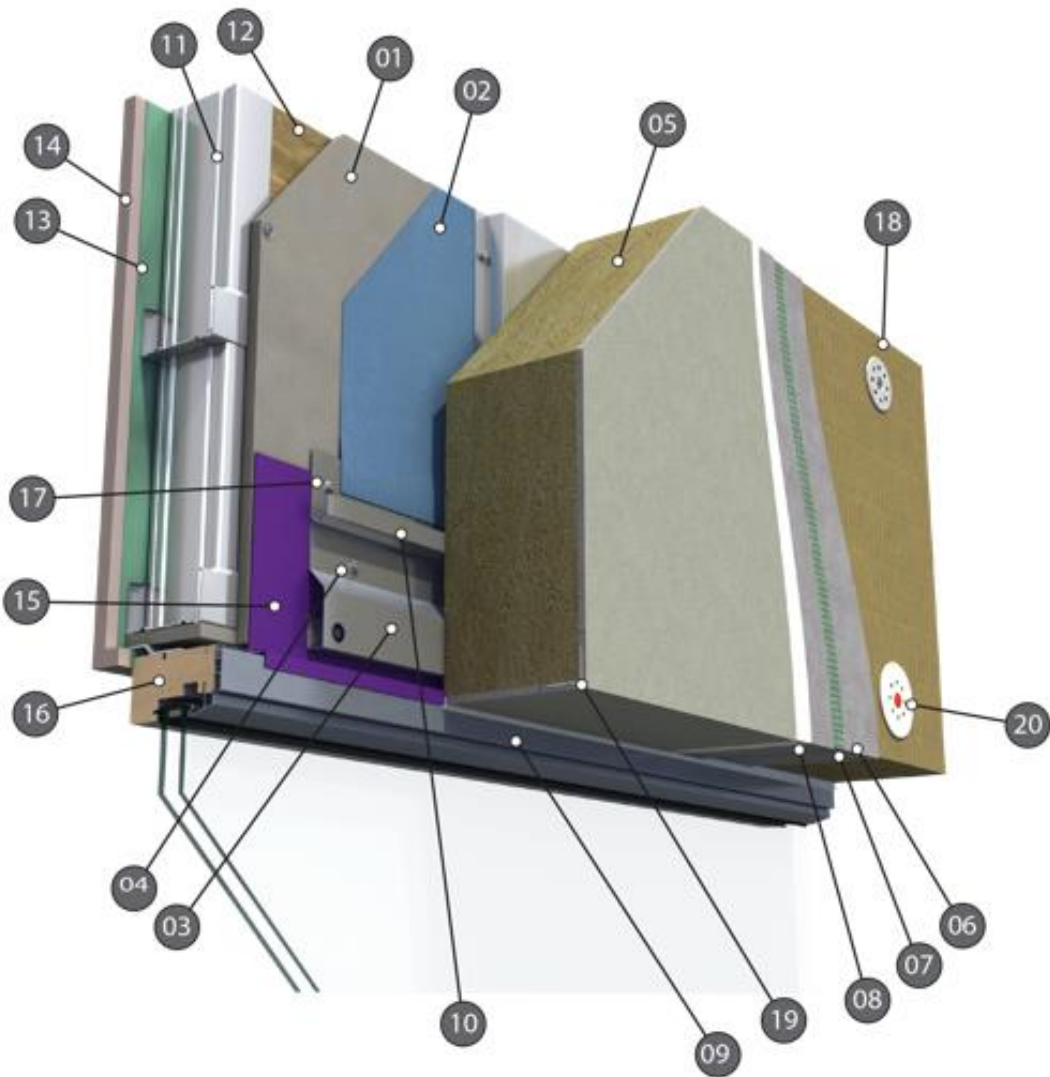

1. Sheathing Board^a
2. Breather Membrane^a
3. Frame Rail
4. Rail Profile Fixing^c
5. Mineral Wool Insulation^b
6. Ceresit Reinforcing Coat^b
7. Two layers of Ceresit Reinforcing Mesh^b
8. Ceresit Primer & Render^b
9. Kilsaran Render Reveal Bead
10. Water Deflection Channel
11. LGS Manufacturer Approved LGS System
12. LGS Manufacturer Approved Insulation
13. LGS Manufacturer Approved AVCL
14. LGS Manufacturer Approved Boarding
15. Kilsaran EPDM Membrane Bonded and Sealed to Approved Sheathing Board
16. Window Frame
17. Stainless Steel Fixing
18. Kilsaran Stainless Steel Fire Fixing^c & Washer Fixed Through the Mesh 1 per m²
19. Kilsaran Corner Bead
20. Kilsaran Fixing^c with 90mm PVC Washer Head

^{a.} Per specification in Section 2.1

^{b.} Per specification in Table 1

^{c.} Per specification in Table 3b

Figure 5: Window Head Detail

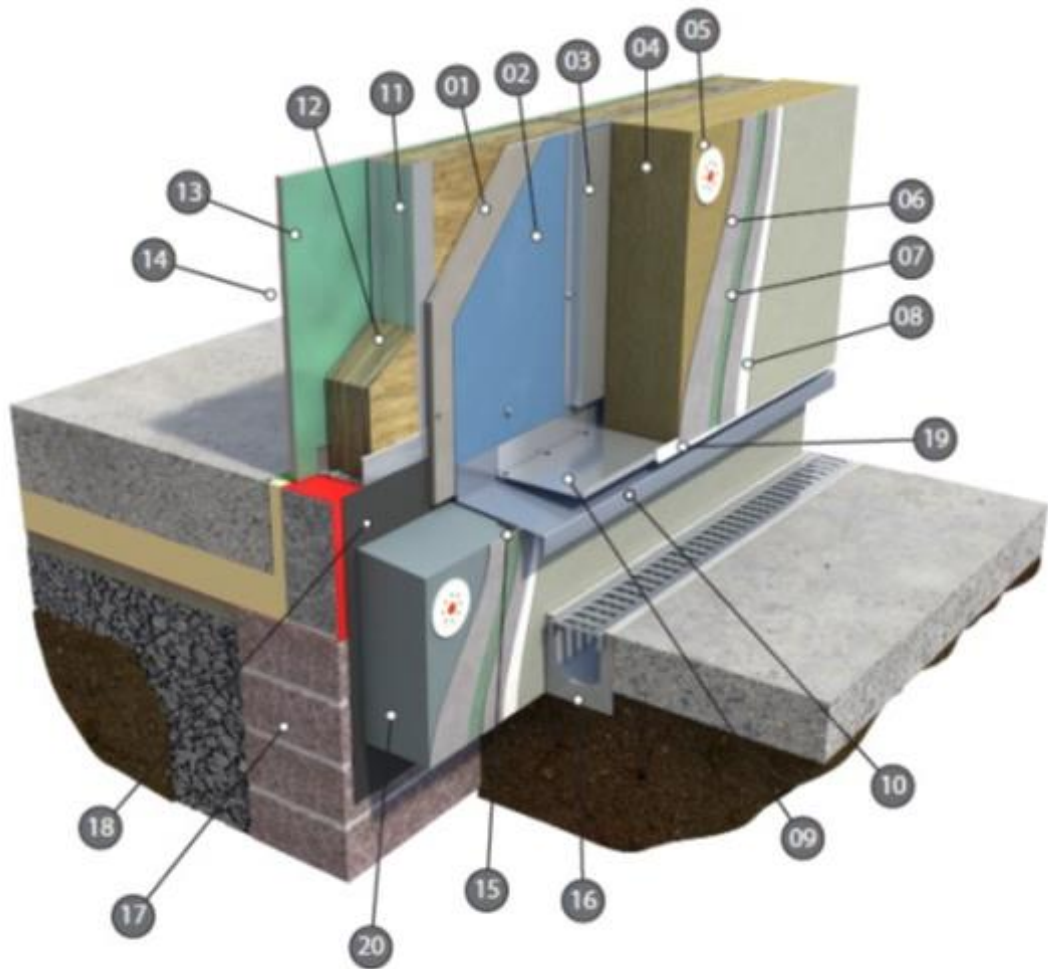

1. Sheathing Board^a
 2. Breather Membrane^a to Drape into Base Rail (9)
 3. Spacer Rail
 4. Rail Profile Fixing^c
 5. Mineral Wool Insulation^b
 6. Ceresit Reinforcing Coat^b
 7. Two layers of Ceresit Reinforcing Mesh^b
 8. Ceresit Primer & Render^b
 9. Kilsaran Perforated Drainage Stainless Steel Base Rail
 10. Kilsaran Plinth Capping
 11. LGS Manufacturer Approved LGS System
 12. LGS Manufacturer Approved Insulation
 13. LGS Manufacturer Approved AVCL
 14. LGS Manufacturer Approved Boarding
 15. Kilsaran Sealant
 16. Drainage as required
 17. LGS Manufacturer Approved Foundation System
 18. Kilsaran EPDM Membrane
 19. Kilsaran Drip Bead
 20. XPS Plinth Insulation^b
- ^{a.} Per specification in Section 2.1
^{b.} Per specification in Table 1
^{c.} Per specification in Table 3b

Figure 6: Base & Plinth Detail

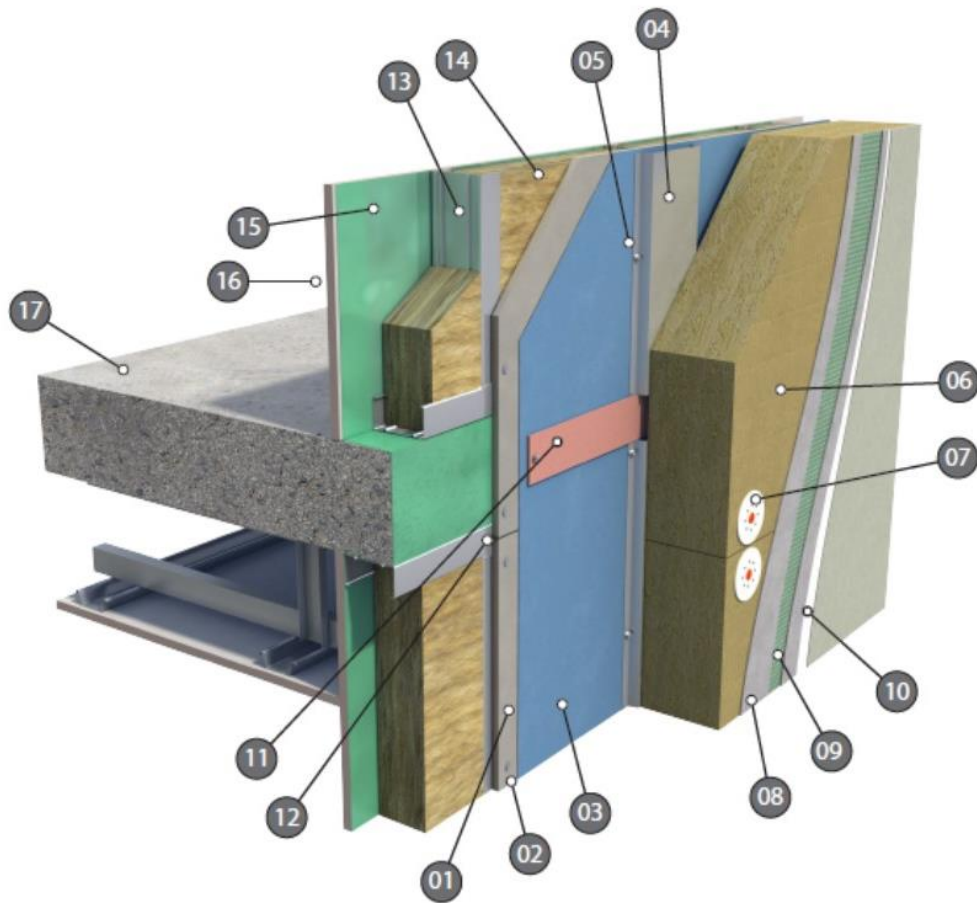

1. Sheathing Board^a
 2. Sheathing Board Stainless Steel Screw^c
 3. Breather Membrane^a
 4. Spacer Rail
 5. Rail Profile Fixing^c
 6. Mineral Wool Insulation^b
 7. Kilsaran Fixing^b with 90mm PVC Washer Head
 8. Ceresit Reinforcing Coat^b
 9. Two layers of Ceresit Reinforcing Mesh^b
 10. Ceresit Primer & Render^b
 11. TENMAT FF102/50 Open State Fire Barrier
 12. Kilsaran Intumescent Sealant
 13. LGS Manufacturer Approved LGS System
 14. LGS Manufacturer Approved Insulation
 15. LGS Manufacturer Approved AVCL
 16. LGS Manufacturer Approved Boarding
 17. LGS Manufacturer Approved Separating Floor System
- ^a. Per specification in Section 2.1
^b. Per specification in Table 1
^c. Per specification in Table 3b

Figure 7: Non-Combustible Separating Floor Detail

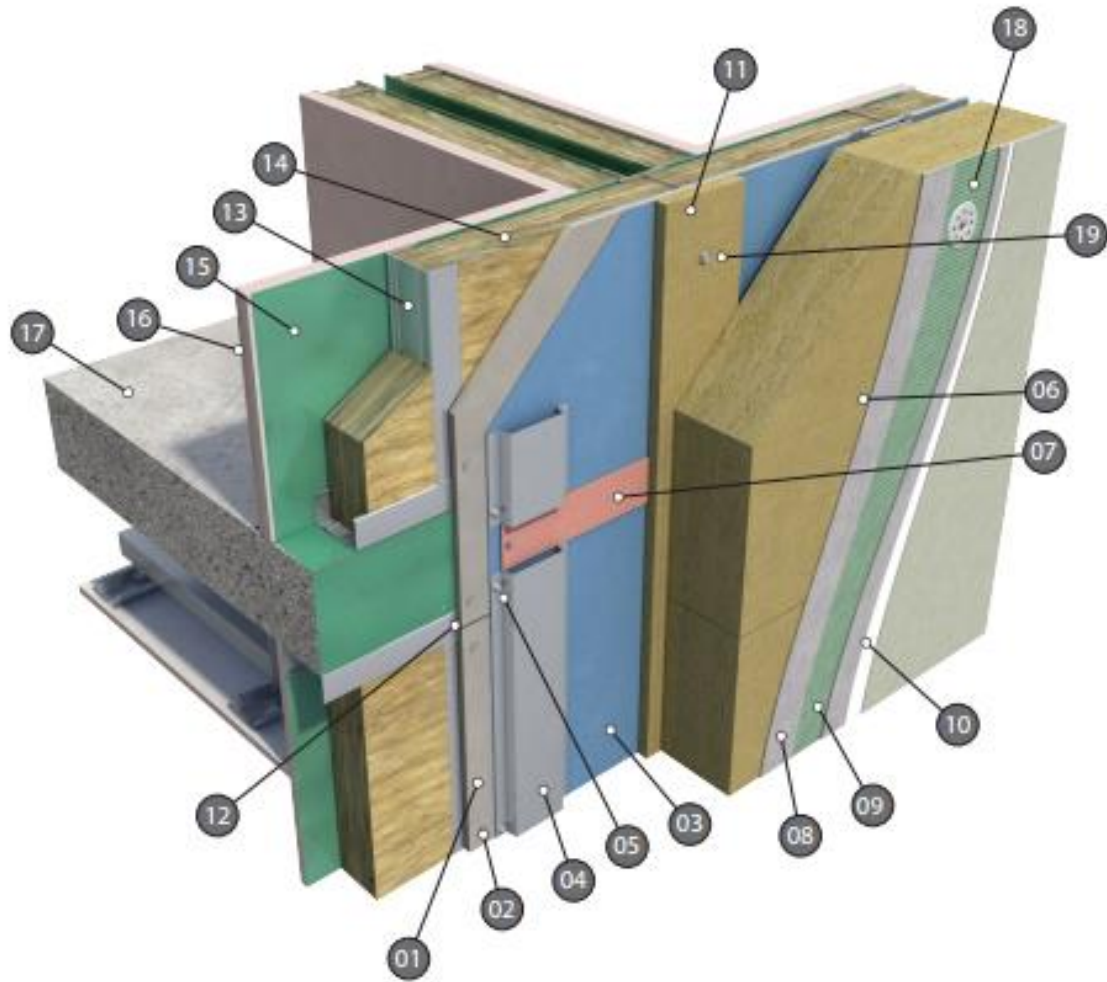

1. Sheathing Board^a
 2. Sheathing Board Stainless Steel Screw^c
 3. Breather Membrane^a
 4. Spacer Rail
 5. Rail Profile Fixing^c
 6. Mineral Wool Insulation^b
 7. Tenmat FF102/50 Open State Fire Barrier
 8. Ceresit Reinforcing Coat^b
 9. Two layers of Ceresit Reinforcing Mesh^b
 10. Ceresit Primer & Render^b
 11. Kilsaran Vertical Fire Barrier to Manufacturer's Specification
 12. Kilsaran Intumescent Sealant
 13. LGS Manufacturer Approved LGS System
 14. LGS Manufacturer Approved Insulation
 15. LGS Manufacturer Approved AVCL
 16. LGS Manufacturer Approved Boarding
 17. LGS Manufacturer Approved Separating Floor System
 18. Kilsaran Stainless Steel Fixing^{ac} Fixed Through the Mesh, minimum 1 per m²
 19. Kilsaran Mechanical Fixing to Secure Vertical Fire Barrier
- ^{a.} Per specification in Section 2.1
^{b.} Per specification in Table 1
^{c.} Per specification in Table 3b

Figure 8: Vertical and Horizontal Fire Barrier Detail

3.1 GENERAL

The KEWI system is designed by Kilsaran on a project specific basis. The design will include for:

- a) The completion and recording of a site survey.
- b) Minimising risk of condensation in accordance with the recommendations of BS 5250^[1].
- c) Thermal insulation provision to Part L of the Building Regulations 1997 to 2021.
- d) Resistance to impact and abrasion.
- e) Provision of movement joints.
- f) Resistance to wind loading.
- g) Design of fixings to withstand design wind loadings. In addition, fixings around window and door openings shall be at a maximum of 300mm centres in each board or section of board so as to provide positive and robust restraint over the life of the system.
- h) Design for fire resistance, fire spread and fire stopping, as defined in Section 3.3 of this Certificate.
- i) Design of a water management system to prevent ingress of water at movement joints, windows, doors, openings for services etc, including the drained cavity between the carrier board and external insulation. Particular attention is required to ensure that window and sill design are coordinated to achieve a fully integrated design.
- j) Movement joints.
- k) Maintenance programme.
- l) Durability requirements.

Consideration should be given to the tensile/flexural strength of the insulation boards spanning the cavity rail system.

Detailing and construction must be to a high standard to prevent the ingress of water and to achieve the design thermal performance.

Window details should be designed such that, where possible, they can be removed and replaced from within the building.

When designed and installed in accordance with this Certificate, the system will satisfy the requirements of Part L of the Building Regulations 1997 to 2021. The design shall include for the elimination/minimising of cold bridging at window and door reveals, eaves and at ground floor level in compliance with Acceptable Construction Details published by the DHLGH.

Seals to windows and doors shall be provided in accordance with the general design. Care should be taken to ensure that any ventilation or drainage openings are not obstructed. Where the

aluminium window sills are face fixed to the window frame, a compressible gasket must be used to create a weathertight seal between frame and sill.

As the plinth insulation is to be installed below ground level, the insulation must be XPS boards which are encapsulated in reinforcing coat render.

3.2 STRENGTH AND STABILITY

3.2.1 Wind Loading

KEWI Systems can be designed to withstand the wind pressures (including suction) and thermal stresses in accordance with the Building Regulations 1997 to 2021. The design for wind loading on buildings should be checked by a chartered engineer, employed by Kilsaran, in accordance with Eurocode 1 I.S. EN 1991-1-4^[2]. A general factor of safety in accordance with Eurocode 0 I.S. EN 1990^[11] is applied to design wind loads.

3.2.2 Impact Resistance

a) The KEWI Systems have been classified as Category I and II and are suitable for use as defined in EAD 040083-00-0404 as follows:
Category I: A zone readily accessible at ground level to the public and vulnerable to hard impacts but not subject to abnormally rough use.

Category II: A zone liable to impacts from thrown or kicked objects, but in public locations where the height of the system will limit the size of the impact; or at lower levels where access to the building is primarily to those with some incentive to exercise care.

Category III: A zone not likely to be damaged by normal impacts caused by people or by thrown or kicked objects.

Note: The above classifications do not include acts of vandalism.

In an Irish context, Category II excludes any wall at ground level adjacent to a public footpath but includes one with its own private, walled-in garden. Category III excludes all walls at ground level.

b) The design should include for preventing damage from impact by motor vehicles or other machinery and additional security measures that may be required. Preventive measures such as provision of protective barriers or kerbs should be considered.

c) The KEWI Systems have been classified as Class 1 and Negligible Risk for soft body impact, and Class 2 and Negligible Risk for

hard body impact as defined in CWCT TN 76^[10] as follows:

Class 1: No damage – No damage visible from 1m and any damage visible from closer than 1m unlikely to lead to significant deterioration;

Class 2: Surface damage of an aesthetic nature which is unlikely to require remedial action – Dents or distortion of panels not visible from more than 5m (note visibility of damage will depend on surface finish and lighting conditions, damage will generally be more visible on reflective surfaces), and any damage visible from closer than 5m unlikely to lead to significant deterioration;

Negligible Risk: No material dislodged during test, no damage likely to lead to materials falling subsequent to test, no sharp edges produced that would be likely to cause severe injury to a person during impact and cladding not penetrated by impactor.

3.3 BEHAVIOUR IN RELATION TO FIRE

Systems that achieve a class A2 Reaction to Fire Classification are suitable for use on purpose groups 1(a), 1(b), 1(c), 1(d), 2(a), 2(b), 3, 4(a), 4(b) and 5 as defined in TGD to Part B of the Building Regulations 1997 to 2021.

The NSAI approved LGS structure, supporting the carrier board in the KEWI system, must have appropriate fire testing from inside to out to meet the requirements of Table A2 in TGD to Part B.

The mineral wool insulation and carrier boards used in the KEWI system must have a minimum A2-s1,d0 fire classification and are classed as non-combustible as per Table A7 of TGD to Part B of the Building Regulations 1997 to 2021.

The breather membrane and plastic washers used in the Kilsaran EWI system, are excluded from this limited combustibility rating. The breather membrane must have a minimum B-s1,d0 fire classification. The plastic washers, used when fixing the mineral wool board to the LGS studs, are encased in the non-combustible mineral wool insulation, for fire protection. A fire fixing is installed per m² of insulation board, to take account for the extra duty required under fire conditions.

Vertical and horizontal cavity fire barriers shall be provided at each compartment floor and wall, and must be installed in accordance with manufacturer's instructions and the fire safety strategy of the building.

TENMAT FF102/50 open state cavity barriers are provided where horizontal cavity barriers are required for water management purposes. These are fixed with non-combustible stainless steel fixings at maximum 250mm centres along the centre line of the fire barrier, with the label side facing out into the cavity. There must be a

maximum remaining air gap of 21mm to the back of the cladding panel.

With regard to fire stopping and limitations on use of combustible materials, walls must comply with Sections 3.2, 3.3, 3.4 and 4 of TGD to Part B of the Building Regulations 1997 to 2021, and Sections 3.5, 3.6, 3.7 and 4 of TGD to Part B Volume 2 of the Building Regulations 1997 to 2021. Stainless steel fire fixings must be provided when specified at the rate of one per square metre through the mesh. The fixing design should take account of the extra duty required under fire conditions.

Vertical cavity barriers shall be provided at each compartment wall as defined by the approved fire safety strategy for the building and will be installed by the approved installer. These cavity barriers must be 200mm wide non-combustible mineral wool lamella boards which should be mechanically fixed to the substrate with stainless steel fire fixings at 400mm centres. The cavity barriers shall be continuous and unbroken for the full perimeter of the building. Glass wool is not suitable for use as a firestop (see Clause 3.6.3 of TGD to Part B Volume 2 of the Building Regulations 1997 to 2021 for types of suitable firestop).

3.4 CONDENSATION RISK

An interstitial condensation risk analysis can be carried out on a project by Kilsaran in accordance with BS 5250^[11] and the design modified as appropriate to reduce the risk of interstitial condensation to acceptable levels.

3.5 LIMITING THERMAL BRIDGING

The linear thermal transmittance ' ψ ' (Psi) describes the heat loss associated with junctions and around openings. The certificate holder has carried out ψ -value calculations for a range of thermally bridged junctions.

When **all** bridged junctions within a building comply with the requirements of Table D2 of TGD to Part L, the improved ' γ ' factor of 0.08 can be entered into the DEAP building energy rating (BER) calculation. If **all** junctions can be shown to be equivalent or better than Acceptable Construction Details published by the DHPLG, then the values published in Table D2 apply.

Where either of the above options are shown to be valid, or when the required values cannot be achieved, all relevant details should be recorded on the 'Certificate of Compliance' for that project for use in future BER calculations.

ψ -values for other junctions outside the scope of this certificate should be assessed by an NSAI approved thermal modeller in accordance with the BRE IP 1/06^[4] and BRE Report BR 497^[5] in accordance with Appendix D of TGD to Part L of the Building Regulations 1997 to 2021.

3.6 MAINTENANCE

Adequate provision should be made in the initial design phase for access and maintenance over the life of the system.

The system shall be inspected and maintained in accordance with the Certificate holder's instructions, as detailed in the Repair and Maintenance Method Statement. Initially an inspection should be made within the first 12 months and regularly thereafter. The inspection schedule should include the following items as a minimum:

- Examination of the sealant around openings such as window frames, door frames and ventilation opes. Sealant must be removed and replaced if there are signs of deterioration.
- Visual inspection of the render for signs of cracking, and repair where necessary in line with IS EN 13914^[6] recommendations.
- Visual inspection to ensure all flashings, cappings and sills are performing correctly to shed water from the façade.
- Visual inspection to ensure all downpipes and gutters are watertight and not leaking causing excessive localised water on the façade.
- Any visible streaking on the façade must be thoroughly investigated and resolved.

Necessary repairs should be carried out immediately and must be in accordance with the Certificate holder's instructions. Repairs to plumbing etc. should also be carried out as required to prevent deterioration or damage, and to protect the integrity of the system.

Synthetic finishes may be subject to aesthetic deterioration due to exposure to UV light. They should be re-painted every 18 to 20 years to maintain appearance. Care should be taken to ensure that the synthetic finish used is compatible with the original system (as listed in Tables 1 to 3) and that the water vapour transmission or fire characteristics are not adversely affected.

Sealants shall be subject to regular inspection (at least annually). They should be replaced as required and fully replaced every 18 to 20 years to maintain performance.

3.7 AESTHETIC PERFORMANCE

As with traditional renders, the aesthetic performance of the systems, e.g. due to discolouration, soiling, staining, algal growth or lime bloom, is depended on a range of factors such as:

- Type, colour and texture of surface finish;
- Water retaining properties of the finish;
- Architectural form and detailing;
- Building orientation/elevation;
- Local climate/atmospheric pollution.

Where cleaning of walls is required, for example in the case of algal growth, the procedure in the Kilsaran maintenance document must be followed

which contains detailed information on the removal of algae. It is the building owner/management company's responsibility to inspect the walls every year and clean when required; however the building owner/management company may contract the approved installer to provide this service.

Full consideration should be given at the design stage to all of the above to ensure that the level of maintenance necessary to preserve the aesthetics of the building is acceptable.

3.8 ENVIRONMENTAL NOISE

In order to provide favourable acoustic conditions for residents, the internal ambient noise levels (IANLs) in a residence should not surpass certain limits expressed as sound pressure levels. The limits that are most commonly quoted are given in BS 8233^[7] and the WHO Guidelines for Community Noise. The IANLs are dependent on multiple factors such as the external noise, the sound insulation performance of all the façade elements, the area of each element, workmanship, the ventilation strategy and ventilation elements.

The external wall configurations shown in this Certificate are expected to provide suitable sound insulation performance for most locations, including urban environments. However, if a higher sound insulation performance is sought, additional mass should be added to the wall configuration, which could be achieved by increasing the thickness of external insulation, increasing the amount of boarding internally, using resilient bars etc. Designers shall satisfy themselves that the declared acoustic performance of the product is adequate for specific project location, acoustic conditions, and in accordance with BS 8233^[7]. Indicative values for wall build-ups are provided in Section 4.4

4.1 IMPACT RESISTANCE

Table 3a lists the impact resistance classifications of various build-ups of the KEWI Systems when tested on a masonry or concrete substrate to EAD 040083-00-0404. Table 3b lists the same when tested on the cavity rail, carrier board and LGS system to CWCT TN 76^[10].

4.2 REACTION TO FIRE

Table 2 lists the reaction to fire classification according to IS EN 13501-1^[3] for various build-ups of the KEWI Systems.

4.3 THERMAL PERFORMANCE

Assessments were carried out to verify that the requirements of Part L of the Building Regulations 1997 to 2021 can be achieved using the KEWI system for infill and load bearing LGS structures.

Table 4 of this certificate gives the various elemental wall U-values in W/m²K achieved with varying insulation thickness.

4.4 ACOUSTIC PERFORMANCE

Building Regulations do not address environmental noise. However, laboratory tests were conducted in accordance with EN ISO 10140-2^[8] on various build-ups of the KEWI Systems, and a sample of results are as follows:

- Base wall (not including carrier board) + 2x 110mm mineral wool slab, 8mm base coat with reinforcing mesh, 2mm silicone top coat: $R_w(C;C_{tr}) = 56(-3;-10)$ dB
- 2x 15mm Soundbloc plasterboard + 100mm LGS + 12mm cement board + 90mm mineral wool slab: $R_w(C;C_{tr}) = 50(-2;-6)$ dB

An on-site test was conducted in accordance with EN ISO 16283-3^[9] of a storeroom with no windows and achieved the following:

- 3mm skim + 12.5mm plasterboard + Vapour control membrane + 150mm LGS stud filled with 100mm mineral wool insulation and 50mm cavity + 12mm approved sheathing board + Breather membrane + 20mm drained cavity + 140mm mineral wool slab + 7mm render: $R'_w(C;C_{tr}) = 46(-2;-6)$ dB

It is important to note that the above tests were conducted without any windows, vents or doors in situ.

4.4 DESIGN LIFE

An assessment of the life of the system was carried out. This included an assessment of:

- Design and installation controls;
- Proposed building heights;
- Render thickness and specification;

- Material specifications, including insulant, mesh, beading and fixing specifications;
- Joint design;
- Construction details;
- Maintenance requirements.

The assessment indicates that the system should remain effective for at least 40 years, providing that it is designed, installed and maintained in accordance with this Certificate and the Certificate holder's instructions. Any damage to the surface finish must be repaired immediately and regular maintenance must be undertaken as outlined in Section 3.6 of this Certificate.

It is important to note that the durability of the render system is entirely dependent on the correct installation of the product in accordance with this Certificate, the manufacturer's instructions, IS EN 13914-1^[6] and ongoing care and maintenance as described in Clause 3.6 of this Certificate. Critical details include rendering at window sills, raised features, junctions with eaves and verges, and the use of suitably designed overhangs and flashings. Reference should be made to IS EN 13914-1^[6] for general advice on design.

The durability of the render systems is also influenced by factors such as the colour of the render used, different exposure locations etc. Further information is available by contacting the Certificate holder.

4.5 WEATHERTIGHTNESS

When designed and detailed in accordance with this Certificate, the system will prevent moisture from the ground coming in contact with the insulation. The external render has adequate resistance to water penetration when applied in accordance with the Certificate holder's instructions.

Joint designs, sealant specifications and recommendations for detailing at windows and doors were assessed via CWCT testing and are considered adequate to ensure that water penetration will not occur, assuming that regular maintenance is carried out in accordance with the Certificate holder's instructions.

4.6 PRACTICABILITY

The practicability of construction and the adequacy of site supervision arrangements were assessed and considered adequate. The project specific designs and method statements for application, inspection and repair were reviewed and found to be satisfactory.

4.7 TESTS AND ASSESSMENTS WERE CARRIED OUT TO DETERMINE THE FOLLOWING

- CWCT testing
- Structural strength and stability
- Behaviour in fire
- Impact resistance
- Pull-out resistance of fixings
- Thermal resistance
- Condensation risk
- Site erection controls
- Durability of components
- Dimensional stability of insulants

4.8 OTHER INVESTIGATIONS

- (i) Existing data on product properties in relation to fire, toxicity and the effect on mechanical

strength/stability and durability were assessed.

- (ii) The manufacturing process was examined including the methods adopted for quality control, and details were obtained of the quality and composition of the materials used.
- (iii) Special building details (e.g. ground level, window and door openings, window sill and movement joints) were assessed and approved for use in conjunctions with this Certificate.
- (iv) Site visits were conducted to assess the practicability of installation and the history of performance in use of the product.

Components		Thickness (mm)
Insulation materials	MW-EN 13162-T5-TR15-WS-DS(TH)-MU1-CS(10)10 Reaction to fire Class A1 TR10 or TR15 for MW panels, TR80 or TR100 for MW lamella Rockwool Dual Density EWI mineral wool (disturbed fibre) board and Lamella (lamella wool) strip	50 - 250
Plinth Insulation	XPS 300/500/700 (extruded polystyrene), 2500mm x 600mm, nominal density of 30/35/45kg/m ³ , compressive strength of 300/500/700kN/m ²	30 - 150
Fixings	<ul style="list-style-type: none"> • EJOT JT3-3 5.5 x 35 S16 stainless steel fixings for carrier board to LGS structure • EJOT LS Sapphire 5.5 x 38 A15 Bi Metal carbon coated fixings with EPDM washer for cavity rail onto carrier board. • EJOT JT3-3 5.5 x 35 S16 stainless steel fixings for deflection rails. • EJOT SW8-R 4.8 fixing pins with SPV 6.5x90 90mm plastic washer for insulation onto cavity rail (6 per slab). Each board was given an additional stainless steel fixing of • EJOT TKE6.3mm stainless steel pin and DMT 85/7E 90mm SS washer for additional fire fixing (1 per slab through the glass fibre mesh). 	-
Base coat	CT 80, CT 87	4.0
Glass fibre mesh	CT 325	-
Key coat / Primer	CT 15, CT 16	-
Finishing coats	<p>Ready to use pastes – acrylic binder CT 60 (particle size 1.5mm)</p> <p>Ready to use pastes – silicate binder CT 72 (particle size 1.5, 2.5 mm) CT 73 (particle size 2.0, 3.0 mm)</p> <p>Ready to use pastes – silicone binder CT 74 (particle size 1.5mm) CT 75 (particle size 2.0, 3.0mm)</p> <p>Ready to use pastes – polymer dispersion CT 79 (particle size 1.5mm)</p> <p>Ready to use pastes – silicone-silicate binder CT 174 (particle size 1.5mm) CT 175 (particle size 1.5, 2.5mm)</p>	Regulated by particle size
Decorative coats (Paints)	CT 48, CT 49, CT 54	-

Table 1: Ceresit Ceretherm Render Materials to be used on the KEWI System

Configuration	Maximum declared organic content	Declared flame retardant content	Reaction to fire class according to EN 13501-1
<ul style="list-style-type: none"> Base coat: CT 87 Reinforcing Mesh CT 325 Finishing coats: CT 72, CT 73, CT 79 Decorative coats: CT 48, CT 49, CT 54 	3.35% N/A 17.60% 21.55%	0%	A2 – s1, d0
<ul style="list-style-type: none"> Base coat: CT 80 Reinforcing Mesh CT 325 Finishing coats: CT 60, CT 74, CT 75, CT 174 or CT 175 (with key coat CT 16), or CT 72 or CT 73 (with key coat CT 15) Decorative coats: CT 48, CT 49, CT 54 	1.64% N/A 17.60% 35.65%	0%	

Table 2: Ceresit Ceretherm Render Systems Reaction to Fire

		Single Standard Mesh CT 325
Rendering System: Base Coat CT 87 + finishing coat indicated hereafter	CT 72, CT 73	Category II
	CT 79	Category I
Rendering System: Base Coat CT 80 + finishing coat indicated hereafter	CT 60	Category II
	CT 74, CT 75	Category III
	CT 174, CT 175	Category III
	CT 72	Category II
	CT 73	Category III

Note: Values obtained when tested on masonry substrate per EAD 040083-00-0404

Table 3a: Impact Resistance (EAD 040083-00-0404)

	Test Type	Test Results
Soft Body	Serviceability, 120J at 245mm drop height	Class 1
	Safety, 500J at 1020mm drop height	Negligible Risk
Hard Body	Serviceability, 10J at 1020mm drop height	Class 2
	Safety, 10J at 1020mm drop height	Negligible Risk

Full build-up as follows:

- LGS Frame:** LGS 89mmx46mmx1.5mm at 600mm centres.
- Boarding:** Boarded with 3 types of Kilsaran approved 12mm fibre cement board. All fixed at 300mm c/c using EJOT JT3-3 5.5 x 35 S16 Stainless Steel Fixings. Board joints were given bead of Nullfire FS 702 sealant.
- Breather Membrane:** Kilsaran approved breather membrane was fitted over the sheathing boards.
- Cavity Rail System:** Kilsaran 20mm cavity rail system consisting of base, corner, deflection and spacer rails. Selected members were fitted as required at 600 centres and fixed through breather membrane into fibre cement boards using EJOT LS Sapphire 5.5 x 38 A15 Bi Metal carbon coated fixings with EPDM washer. Deflection rails were fitted using EJOT JT3-3 5.5 x 35 S16 Stainless Steel Fixings.
- External Insulation:** Rockwool Dual Density EWI slab 150mm fixed to cavity rail system to manufacturer's instruction using EJOT SW8-R 4.8 fixing pin and SPV 6.5x90 90mm plastic washer (6 per slab). Each board was given an additional Stainless Steel fixing of EJOT TKE6.3mm SS pin and DMT 85/7E 90mm SS washer (1 per slab through the glass fibre mesh).
- External Render:** Ceresit CT80 Universal A2 system reinforcing coat applied with 2 layers of Cerest CT325 reinforcing mesh and a render coat of Ceresit CT74 silicone stone.

Table 3b: Impact Resistance (CWCT TN 76)

External walls U-value for variable Mineral Wool thickness		
Wall build-up:		
Layer 1: Render - Ceresit		
Layer 2: Variable Mineral Wool Insulation		
Layer 3: Cavity (Unventilated)		
Layer 4: Approved Carrier Board		
Layer 5: Mineral Wool Insulation/LGS		
Layer 6: 15mm Plasterboard		
Layer 7: Skim		
Total wall thickness	Mineral Wool variable thickness:	Calculated U-value (W/m²K)
286mm	140mm	0.179
296mm	150mm	0.171
306mm	160mm	0.164
316mm	170mm	0.158
326mm	180mm	0.152
336mm	190mm	0.147
346mm	200mm	0.142
Calculation complies with BRE Digest 465 <i>U-values for light steel-frame construction</i> ⁽¹⁾ Correction for mechanical fasteners have been applied to layer 2, equating to 6.94 fixings per m ² (4.8mm Ø carbon steel fixings, 4.8mm Ø stainless steel fixings). This may be subject to change on project specific basis (see Table 5).		

Table 4: Typical External Wall U Value Calculations

Sample U-value Calculation for 140mm Mineral Wool					
Layer	Description	% Bridged	Thickness [mm]	Thermal conductivity λ [W/m K]	Thermal resistance R [W/m ² K]
	Rse				0.040
1	Render - Ceresit		7	0.94	0.007
2	Mineral Wool Insulation		140	0.036	3.889
3	Cavity (Unventilated)	0.0033	20	R 0.180	-
4	Approved Carrier Board		12	0.260	0.046
5	Mineral Wool Insulation / LGS	0.0028	89	0.038	2.342
6	Plasterboard		15	0.250	0.060
7	Skim		3	0.250	0.005
	Rsi				0.13
Ru Total =					6.689
RL Total =					<u>4.751</u>
From BRE Digest 465					$P = 0.653, R_T = pR_{max} + (1 - p)R_{min} =$
					<u>6.016</u>
					Correction term, $\Delta U =$
					<u>0.0127</u>
Corrected U-Value (2DP) =					0.18 W/m ² K

Table 5: Sample U Value Calculation for 140mm Mineral Wool

Target linear thermal transmittance (ψ) for different types of junctions.					
ACD Ref:	Junction Description	Temperature Factor f_{Rsi} (Min = 0.75)	Kilsaran ψ -value (W/m.K)		TGD L Default ψ -value
5.02	Ground Floor – Insulation Below Slab	0.78	0.084	<	0.106
5.03	Intermediate Floor ¹	0.93	0.056	>	0.021
5.18	Parapet	0.90	0.186	>	0.054
5.19	Window Head	0.89	0.039	>	0.006
5.20	Window Jamb	0.88	0.031	>	0.023
5.21	Window Cill	0.83	0.093	>	0.012
5.23.1	External Corner	0.82	0.067	<	0.075
5.23.2	Inverted Corner	0.97	-0.050	<	-0.045

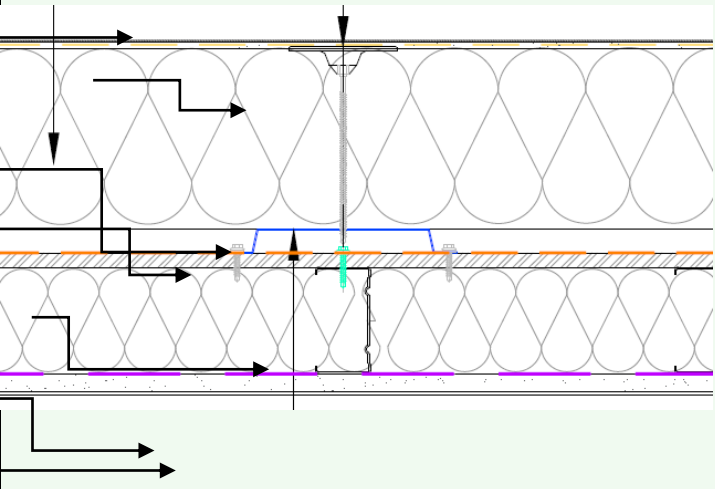
¹Psi value is for the whole junction. Half the value should be applied to each dwelling on either side of the junction.
 Flanking element U-values for walls, roof and floor thermal models above were based on, $U_W = 0.166$ W/m²k, $U_F = 0.174$ W/m²k, $U_R = 0.186$ W/m²k
 Modelled junction ψ -values above can be used in γ -value calculations.
 Values may differ depending on LGS system used.

Table 6: Typical ψ -Values

5.1 National Standards Authority of Ireland ("NSAI") following consultation with NSAI Agrément has assessed the performance and method of installation of the product/process and the quality of the materials used in its manufacture and certifies the product/process to be fit for the use for which it is certified provided that it is manufactured, installed, used and maintained in accordance with the descriptions and specifications set out in this Certificate and in accordance with the manufacturer's instructions and usual trade practice. This Certificate shall remain valid for five years from date of latest revision so long as:

- (a) the specification of the product is unchanged.
- (b) the Building Regulations 1997 to 2021 and any other regulation or standard applicable to the product/process, its use or installation remains unchanged.
- (c) the product continues to be assessed for the quality of its manufacture and marking by NSAI.
- (d) no new information becomes available which in the opinion of the NSAI, would preclude the granting of the Certificate.
- (e) the product or process continues to be manufactured, installed, used and maintained in accordance with the description, specifications and safety recommendations set out in this certificate.
- (f) the registration and/or surveillance fees due to NSAI Agrément are paid.

5.2 The NSAI Agrément mark and certification number may only be used on or in relation to product/processes in respect of which a valid Certificate exists. If the Certificate becomes invalid the Certificate holder must not use the NSAI Agrément mark and certification number and must remove them from the products already marked.

5.3 In granting Certification, the NSAI makes no representation as to;

- (a) the absence or presence of patent rights subsisting in the product/process; or
- (b) the legal right of the Certificate holder to market, install or maintain the product/process; or

(c) whether individual products have been manufactured or installed by the Certificate holder in accordance with the descriptions and specifications set out in this Certificate.

5.4 This Certificate does not comprise installation instructions and does not replace the manufacturer's directions or any professional or trade advice relating to use and installation which may be appropriate.

5.5 Any recommendations contained in this Certificate relating to the safe use of the certified product/process are preconditions to the validity of the Certificate. However the NSAI does not certify that the manufacture or installation of the certified product or process in accordance with the descriptions and specifications set out in this Certificate will satisfy the requirements of the Safety, Health and Welfare at Work Act, or of any other current or future common law duty of care owed by the manufacturer or by the Certificate holder.

5.6 The NSAI is not responsible to any person or body for loss or damage including personal injury arising as a direct or indirect result of the use of this product or process.

5.7 Where reference is made in this Certificate to any Act of the Oireachtas, Regulation made thereunder, Statutory Instrument, Code of Practice, National Standards, manufacturer's instructions, or similar publication, it shall be construed as reference to such publication in the form in which it is in force at the date of this Certification.

NSAI Agrément

This Certificate No. **21/0429** is accordingly granted by the NSAI to **Kilsaran** on behalf of NSAI Agrément.

Date of Issue: **19th November 2021**

Signed

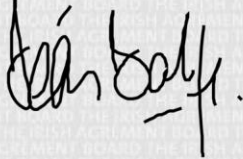

Seán Balfe
Director of NSAI Agrément

Readers may check that the status of this Certificate has not changed by contacting NSAI Agrément, NSAI, 1 Swift Square, Northwood, Santry, Dublin 9, Ireland. Telephone: (01) 807 3800. Fax: (01) 807 3842. www.n Sai.ie

Bibliography

- [1] BS 5250:2016 *Code of practice for control of condensation in buildings.*
- [2] I.S. EN 1991-1-4:2005 *Actions on structures – General actions – Wind actions.*
- [3] IS EN 13501-1:2007 *Fire classification of construction products and building elements – Classification using data from reaction to fire tests.*
- [4] BRE IP 1/06 *Assessing the effects of thermal bridging at junctions and around openings.*
- [5] BRE BR 497 *Conventions for calculating linear thermal transmittance and temperature factors.*
- [6] IS EN 13914-1:2016 *Design, preparation and application of external rendering and internal plastering – External rendering.*
- [7] BS 8233: 2014 *Guidance on sound insulation and noise reduction for buildings.*
- [8] EN ISO 10140-2:2021 *Acoustics – Laboratory measurement of sound insulation of building elements – Part 2: Measurement of airborne sound insulation.*
- [9] EN ISO 16283-3:2016 *Acoustics – Field measurement of sound insulation in buildings and of building elements – Part 3: Façade sound insulation.*
- [10] CWCT Technical Note 76 *Impact performance of building envelopes: Method for impact testing of cladding panels.*
- [11] I.S. EN 1990:2014 *Eurocode – Basis of structural design.*